

Islam is
My Religion
(upto 7 years)

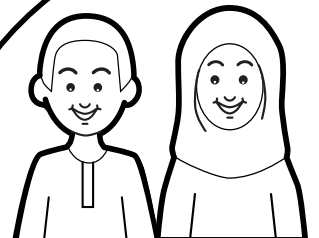

CONTENTS

Dua Before Starting A Lesson.....	1
Islam Is My Religion.....	2
I Am A Muslim.....	4
Tawheed.....	6
Who is Allah?	7
Who Taught Her to Cry?	9
Allah Made Us All.....	10
What Made You Believe in Allah?	11
Adala (Justice)	14
Nabuwwa (Prophet hood)	15
Who is a Prophet.....	18
Imama.....	19
Qiyama.....	23
Words Used in Fiqh and Their Meaning - 1.....	29
Taqleed.....	32
Najasaat.....	33
Mutahhiraat.....	34
Manners and Tahara In The Toilet.....	36
Wudhu.....	37
Qibla.....	40
Place For Salaa.....	41
Clothes For Salaa.....	43
Times For Salaa.....	44



Salaa.....	46
Adhan.....	50
Iqama.....	52
The First Mu'adhin.....	55
Number Of Rakaats And Times Of Salaa (Namaz).....	59
This Is How I Pray Salaa (Namaz)	60
Qunoot.....	66
Ta'qibaat.....	68
Remembering Allah All The Time.....	69
Insha Allah.....	70
I Am Going To Buy A Cow.....	71
Lying.....	73
A Big Purple Dog.....	74
Less Wanting.....	76
Manners Of Talking.....	77
Anger.....	79
Be Cheerful.....	82
Do Not Abuse.....	84
End Of A Friendship.....	86
Do Not Belittle Others	87
Big and Small Sins.....	90
Watching TV.....	92
Duties Towards Parents.....	93
Manners Of Reciting The Qur'an.....	94
The Qur'an.....	95
Suratul Kawthar.....	98

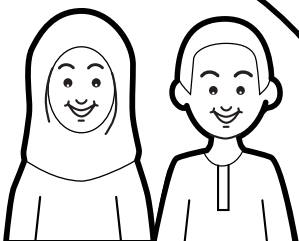

Suratul 'Asr.....	100
Suratul Lahab.....	102
Suratul Feel.....	105
Prophet Dawad(pbuh)	108
Prophet Dawad (pbuh) - Nineteen Sons.....	111
Prophet Sulayman (pbuh) - The Valley Of Ants.....	113
Prophet Sulayman (pbuh).....	115
Prophet Sulayman (pbuh)	
“O Sulayman! At this moment of time, I am better than you” ...	118
Prophet Yunus (pbuh) - The Big Fish.....	120
Prophet Ibraheem (pbuh) - Say: Bismillahir rahmaanir raheem	123
Prophet Ibraheem (pbuh) - Khalilullah.....	125
Prophet Muhammad (pbuh).....	126
Prophet Muhammad (pbuh) - Amr – Hashim.....	134
Prophet Muhammad (pbuh) – Abdul Muttalib Shaybatul Hamd	135
Aamul Feel The Year Of The Elephant.....	137
Hazrat Abdullah (pbuh) & Sayyida Amina (pbuh).....	139
Birth Of Prophet Muhammad (pbuh).....	141
Prophet Muhammad (pbuh) - It's Magic.....	143
Al – Amin (The Trustworthy One)	144
Announcement Of Prophethood.....	146
Prophet Muhammad (pbuh) - Me'raj.....	150
Prophet Muhammad (pbuh) – Hijra To Madina.....	153
Farewell Hajj.....	154
A Very Special Announcement.....	156
Prophet Muhammad (pbuh) - Salaa! Salaa.....	158

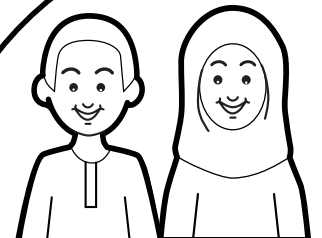

Sayyida Fatima - Az – Zahra (pbuh).....	159
1 – Imam Ali (pbuh).....	163
2 – Imam Hasan (pbuh).....	166
3 – Imam Husayn (pbuh).....	169
4 – Imam Ali Zaynul Aabideen (pbuh).....	173
5 – Imam Muhammad Al –Baqir (pbuh).....	176
6 – Imam Ja’fer As – Sadiq (pbuh).....	180
7 – Imam Musa Al – Kadhim (pbuh).....	184
8 – Imam Ali Ar –Ridha (pbuh).....	187
9 – Imam Muhammad At – Taqi (pbuh).....	191
10 – Imam Ali An – Naqi (pbuh).....	194
11 – Imam Hasan Al – Askery (pbuh).....	195
12 – Imam Muhammad Al – Mahdi (pbuh).....	198
The Islamic Year.....	202
Assessment.....	208
Islam Is My Religion.....	213

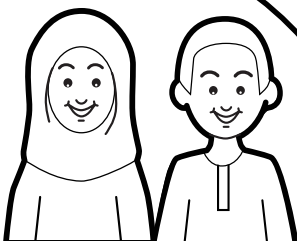

DUA BEFORE STARTING A LESSON

Mafatihul Jinaan – Pg 490

بِسْمِ اللَّهِ الرَّحْمَنِ الرَّحِيمِ

I begin in the name of Allah, the Kind, the Merciful

اللَّهُمَّ أَخْرِجْنِي مِنَ ظُلُمَاتِ الْوَهْمِ

O Allah! Take me out from the darkness of doubt (conjecture)

وَ أَكْرِمْنِي بِنُورِ الْفَهْمِ

And favour me with the light of understanding

اللَّهُمَّ افْتَحْ عَلَيْنَا أَبْوَابَ رَحْمَتِكَ

O Allah! Open for us the doors of Your mercy

وَ انشُرْ عَلَيْنَا خَزَائِنَ عُلُومِكَ

And unfold for us the treasures of Your knowledge

بِرَحْمَتِكَ يَا أَرْحَمَ الرَّاحِمِينَ

With Your mercy, O the Most Merciful of the Merciful

اللَّهُمَّ صَلِّ عَلَى مُحَمَّدٍ وَ آلِ مُحَمَّدٍ

O Allah! Send Your blessings on Muhammad and his ahlulbayt

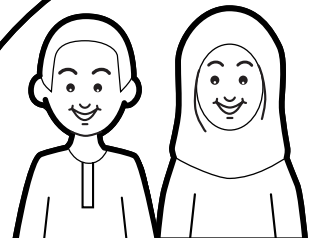

ISLAM IS MY RELIGION

The word Islam comes from the Arabic word 'salama' which means 'peace' or 'submission'...

A Muslim is therefore one who is at peace with (who submits to) Allah.

If you want peace at home, you listen to what your parents say and obey them. In the same way to be at peace with Allah one has to obey Him.

The Prophet (pbuh) was asked what Islam is in one sentence. He said: "Obeying the Creator and serving His creation."

Religion has been described as a tree. For a tree to survive it needs strong roots. In Arabic, roots are called (Usool).

There are five roots of religion, which are what we believe in:

1. Tawheed - There is only one God.
2. Adala - Allah is just.
3. Nabuwwa - Allah sent prophets to guide us.
4. Imama - After the last Prophet -Muhammad (pbuh) there are 12 leaders chosen by Allah - the Imam of our time being Imam Muhammad Al-Mahdi (pbuh)
5. Qiyama - The day of judgement when each person will rise again and account for his/her life.

There is no taqleed (following a mujtahid) in Usool.

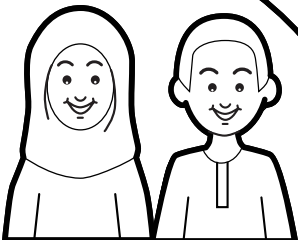

A tree with just roots is not a complete tree. It needs branches. The branches of religion are called furu, there are 10 branches (furu) of religion.

The ten branches of religion are:

1. Salaa
2. Sawm
3. Hajj
4. Zaka
5. Khums
6. Jihad
7. Amr bil Ma'ruf
8. Nahyi anil Munkar
9. Tawalla
10. Tabarra

The branches portray the a'mal - actions (deeds) required to be performed by a Muslim.

In Arabic the laws of Islam by which one can perform the furoo is known as Shari'a.

A tree is only complete if it has both roots and branches. In the same way Islam is a complete way of life composed of both beliefs and a'mal – actions.

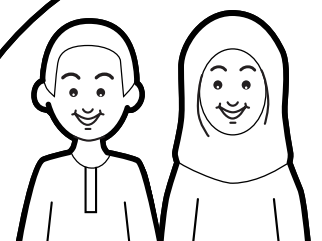

I AM A MUSLIM

لَا إِلَهَ إِلَّا اللَّهُ

There is no God except Allah

مُحَمَّدٌ رَسُولُ اللَّهِ

Prophet Muhammad is the messenger of Allah

عَلِيٌّ وَوَلِيُّ اللَّهِ

Imam Ali is the loved one of Allah

وَصِيِّ رَسُولِ اللَّهِ

He is the successor (leader after) of the messenger of Allah

وَ خَلِيفَتُهُ بِأَفْصَلِ

And he is the first khalifa (chosen leader).

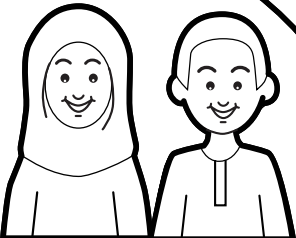

Activity Sheet (Kalima)

Match the columns below:

رَسُولُ اللَّهِ

لَا إِلَهَ

إِلَّا اللَّهُ

عَلَيَّ

وَلِيُّ اللَّهِ

مُحَمَّدٌ

بِلاَ فَصْلٍ

وَمَهِيَّ

رَسُولُ اللَّهِ

وَخَلِيفَتُهُ

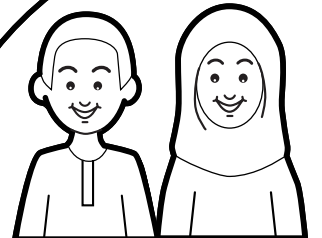

TAWHEED

This is the first root of religion – Usul e deen

Tawheed means one. It is believing that there is only one God - Allah.

Unlike the word God which can be made into Gods and Goddess, there is no plural of the word Allah and neither is there a feminine of the word Allah.

Besides believing that there is only one God, Tawheed means to reject all other idols - physical or mental.

One who believes in Tawheed does everything for none but Allah.

Imam Ali (Pbuh) has said:

"...We must believe that Allah is One... He knows everything, hears everything and sees everything. He has no physical form, and cannot be seen by one's eyes in the world and in the hereafter...He is not in a particular place but there is no place where Allah is not present...He is Just (fair) but He is also Kind and Merciful..."

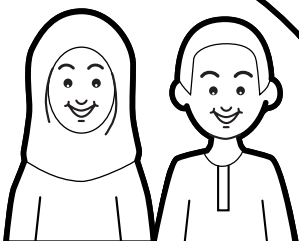

WHO IS ALLAH?

The people kept asking Prophet Muhammad (pbuh) who Allah was?

Does He have parents?

Does He have a partner?

Does He need anything?

Is there someone or something like Him?

The angel Jibraail brought the following ayaat of the Qur'an from Allah to answer their questions.

بِسْمِ اللّٰهِ الرَّحْمٰنِ الرَّحِیْمِ

قُلْ هُوَ اللّٰهُ اَحَدٌ

اللّٰهُ الصَّمَدُ

لَمْ يَلِدْ وَّ لَمْ يُولَدْ

وَّ لَمْ يَكُنْ لَّهٗ كُفُوًا اَحَدٌ

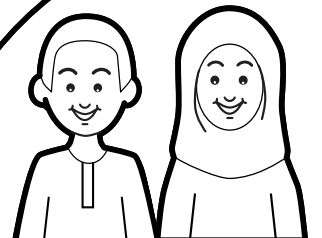

(I begin in the name of Allah, the Kind, the Merciful.)

Say! He Allah is One.

Allah – the Independent (The One on whom all depend)

He does not give birth and neither was He given birth to

And there is none like Him.

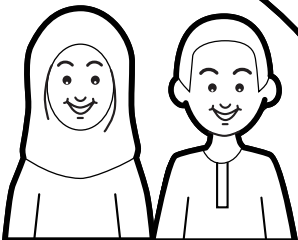

WHO TAUGHT HER TO CRY?

Abbas watched his new baby sister. She had tiny little hands that gripped his finger tightly.

"She is so perfect, mum!" he said.

"Subhanallah! Allah makes everything perfect" mum replied.

Suddenly baby Sarah started to screw her face up and cry. Abbas got worried and looked up at his mother.

"Mum, why is she crying?" he said

"I think she is hungry" mum said and picked up Sarah to feed her.

"Who taught her to cry, mum? Abbas asked.

"It is Allah who taught this little baby to cry, she cannot speak so she cries whenever she wants anything so that someone will come to help!" mum replied.

"Allahu Akber! Allah is so great and so kind" said Abbas. "I Love Him very much!"

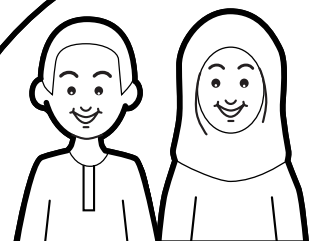

ALLAH MADE US ALL

Allah made me and He made you. Allah made everything from the smallest creatures to the highest mountains.

He looks after all His creation. Because He is greater than anything and anyone, He can look after all of us at the same time.

اللَّهُ أَكْبَرُ

Allah is Greater (than anything and anyone)

Allah is my Rabb and your Rabb too. Allah is the Rabb of everyone everywhere. Allah is the Rabb of the worlds. Rabb is one who looks after us like no-one else.

الْحَمْدُ لِلَّهِ رَبِّ الْعَالَمِينَ

All praise is for Allah, the Rabb of the worlds.
All of us depend on Allah for everything.

اللَّهُ الصَّمَدُ

It is Allah who makes me grow from a baby in the cradle to an adult. Every year I have a birthday. I grow a little from the last year. I learn a little more and I try to become a better Muslim.

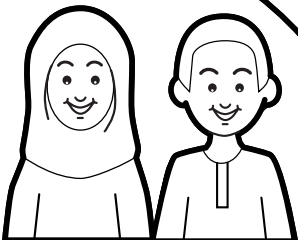
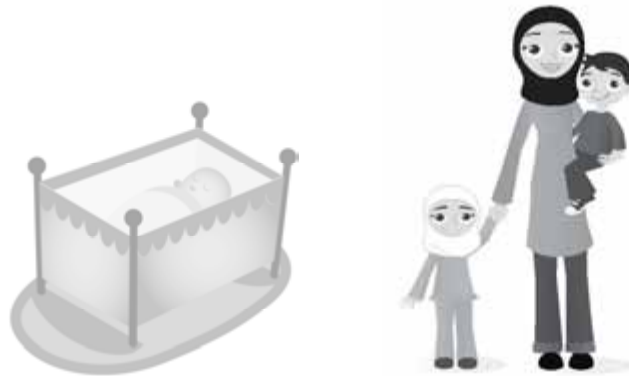

“WHAT MADE YOU BELIEVE IN ALLAH?”

Prophet Muhammad (pbuh) was once walking with his companions when he saw an old lady working at a spinning wheel. Whilst she was working she was praising Allah for all that He had given her.

The Prophet (pbuh) greeted her and asked her:
“Your faith is admirable; will you tell me what made you believe in Allah?”

The woman answered:
“O Messenger of Allah! If I do not move my spinning wheel, it does not spin.

If a simple thing like my spinning wheel cannot turn without help how can it be possible that the whole universe can operate so efficiently without a driving force. There must be a Great one running it. Someone who controls every atom.

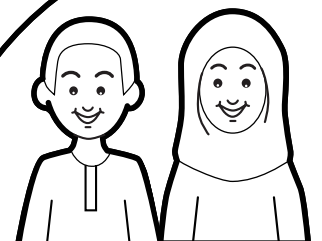

The Great One can only be Allah, who is the Creator and Master of everything.”

The Prophet (pbuh) was very pleased with the old woman’s reply. Turning to his companions he said:

“See how this old lady came to know about Allah through such a fine and simple way. Your faith in Allah should also be as firm as hers.

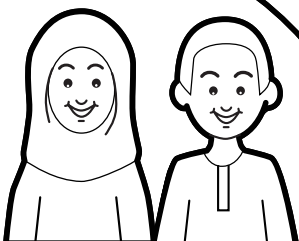

Allah's wonderful creations

Colour the pictures below:

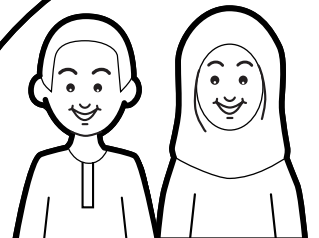
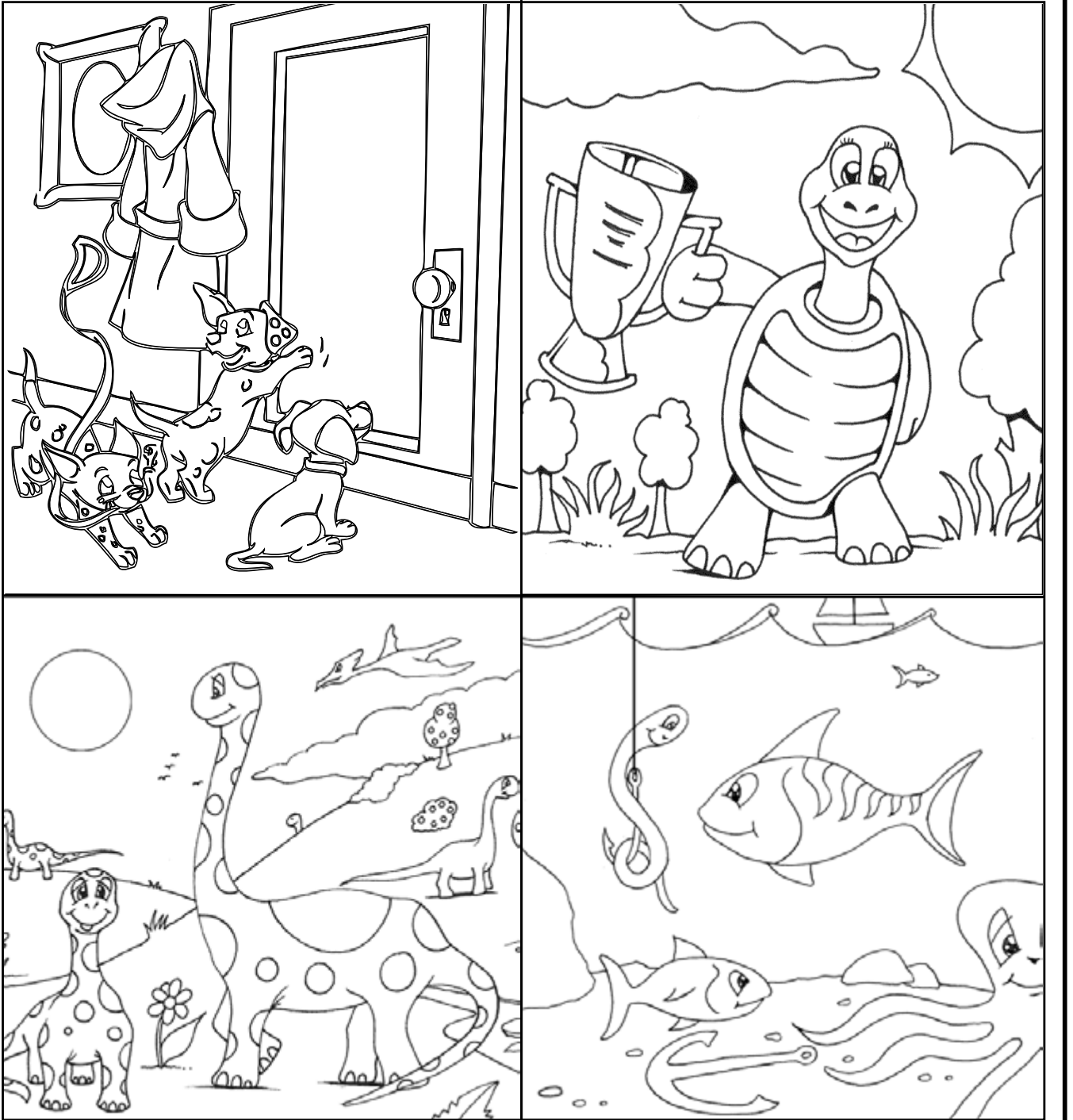

ADALA (JUSTICE)

Adala means to put everything in it's right place. If you were to wear your shoes on your head than it would not be an act of adala – justice.

Sometimes we confuse adala with being equal. If everyone in the classroom was given the same marks in their test, whether they did well or not, it would not be fair (just) although everyone would get equal marks.

To believe in adala of Allah means to believe that:

1. Allah is fair to everyone. He never does anything wrong.
2. He never forces anyone to do bad things and then punish them.
3. He will always reward those who obey Him.

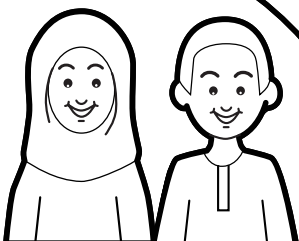

NABUWWA (Prophethood)

This is the third root of religion.

According to Islamic terminology the word nabi means one who is sent by Allah to guide us. A rasul is one who is sent by Allah and brings a new shari'a (Laws of living). In the English language both nabi (pl. Ambiya) and rasul (pl. Mursaleen) are referred to as Prophets.

Allah sent 124,000 Prophets to guide us. The first of them was Prophet Adam (pbuh) and the last one was Prophet Muhammad (pbuh)

Many of the Prophets were sent to one or two villages, some even to one family. Others were sent to a bigger area or to one tribe. But none of them were sent for the whole of mankind like our Prophet Muhammad (pbuh)

Five of these Prophets are known as **Ulul Adhm Prophets** (those given a great responsibility). They are:

- 1) Prophet Nuh (pbuh)
- 2) Prophet Ibraheem (pbuh)
- 3) Prophet Musa (pbuh)
- 4) Prophet Isa (pbuh)
- 5) Prophet Muhammad (pbuh)

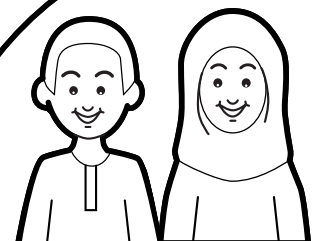

Allah sent down words to guide us.
These words were written down into books.
There were many books.
The four important ones are:
Zabur given to Prophet Dawud (pbuh)
Tawraat given to Prophet Musa (pbuh)
Injeel given to Prophet Isa (pbuh)
Qur'an given to Prophet Muhammad (pbuh)

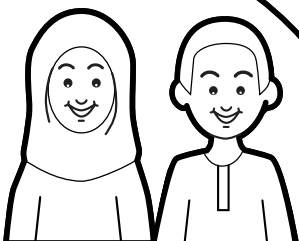

Prophets

Match the columns below:

**Prophet Muhammad
(pbuh)**

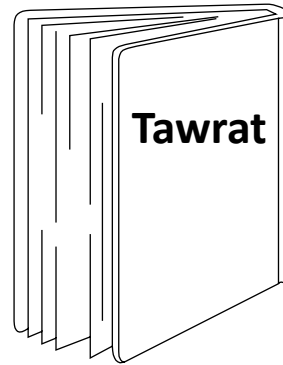

Prophet Isa (pbuh)

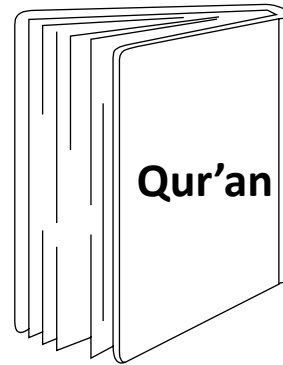

Prophet Dawud (pbuh)

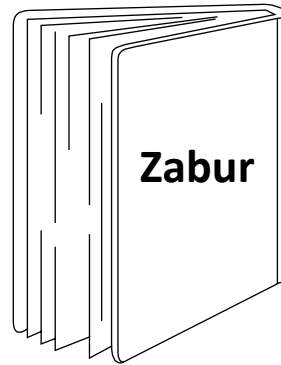

Prophet Musa (pbuh)

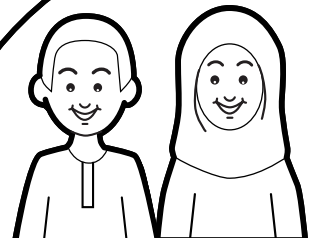
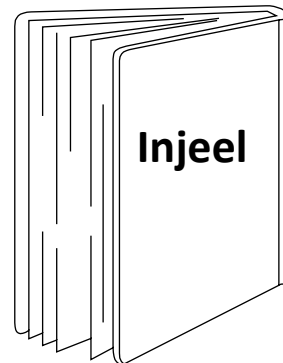

Who is a Prophet?

A Prophet must be the perfect person in his time in everything like knowledge, akhlaq, taqwa, bravery.....

He must also have the following qualifications:

1. He must be sent by Allah. A Prophet cannot be chosen by the people.
2. He must have عِصْمَةٌ -'isma. This means that he must not do anything to displease Allah even by mistake. A Prophet therefore does not commit any sins.
3. He must be able to perform miracles - مُعْجَزَةٌ A miracle is something that nobody else can do. Miracles are performed by permission of and power given by Allah. The miracles of Prophet Musa (pbuh) are that his staff turned into a snake whenever he threw it down and his hand shone like a lamp every time he placed it under his armpit and took it out. The miracles of Prophet Isa (pbuh) are that he could cure the sick and bring the dead back to life. The miracle of our Prophet Muhammad (pbuh) is the Qur'an.



IMAMA

This is the fourth root of religion.

Imama means 'to lead'. An Imam is therefore a Leader.

The plural of Imam is AImma.

There are 12 AImma. The first of them being Imam Ali (pbuh) and the last, the Imam of our time being Imam Muhammad Al-Mahdi (pbuh)

Just like a Prophet, the Imam must be the most perfect person in his time in everything.

Our Prophet Muhammad (pbuh) built Islam up till it was perfect, just like a builder who builds a building to it's completion. AImma are then those who look after the religion as caretakers, just as a building requires a caretaker to look after it and maintain it.

AImma must be chosen by Allah. They cannot be chosen by the people.

They too must have 'Isma - They must not do anything to displease Allah even by mistake.

They must also be able to perform miracles.

There are twelve AImma

1. Imam Ali (pbuh)
2. Imam Hasan (pbuh)
3. Imam Husayn (pbuh)

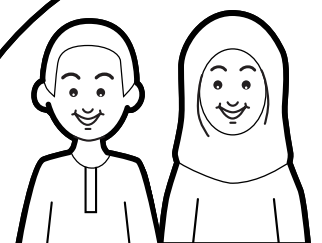

4. Imam Ali Zaynul Abedeen (pbuh)
5. Imam Muhammad Al-Baqir (pbuh)
6. Imam Ja'fer As-Sadiq (pbuh)
7. Imam Musa Al-Kadhim (pbuh)
8. Imam Ali Ar-Ridha (pbuh)
9. Imam Muhammad At-Taqi (pbuh)
10. Imam Ali An-Naqi (pbuh)
11. Imam Hasan Al-Askery (pbuh)
12. Imam Muhammad Al-Mahdi (pbuh)

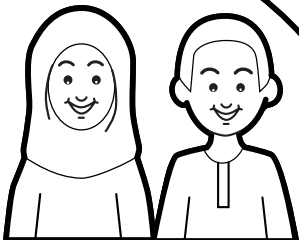
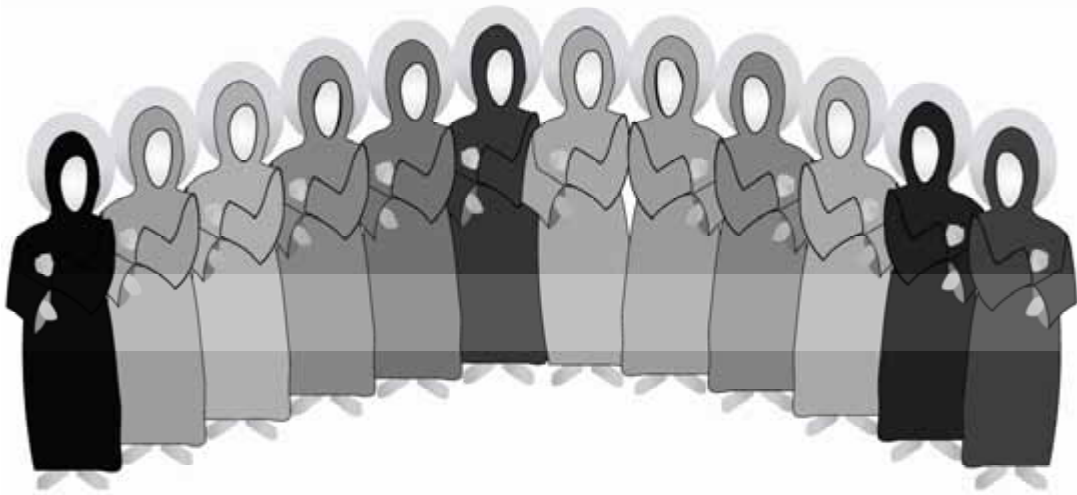

Imama Quiz

Match the columns:



Imam Hasan (pbuh)



Imam Muhammad Taqi (pbuh)



Imam Husayn (pbuh)



Imam Hasan Askery (pbuh)



Imam Ali (pbuh)



Imam Musa Kadhim (pbuh)



Imam Ali Zaynul Abedeen (pbuh)



Imam Ja'fer Sadiq (pbuh)



Imam Muhammad Baqir (pbuh)



Imam Muhammad Mahdi (pbuh)



Imam Ali Ridha (pbuh)



Imam Ali Naqi (pbuh)

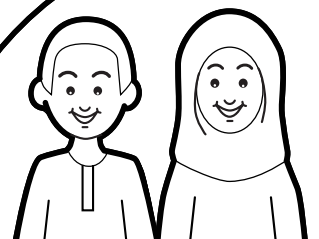

Imama Quiz

Match the cups to the teapot:

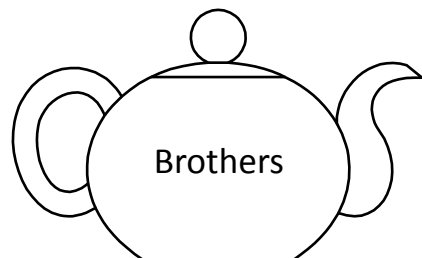
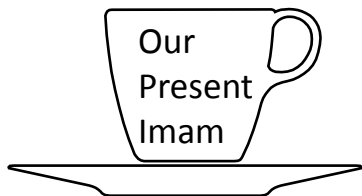
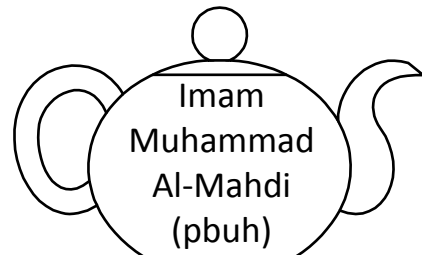
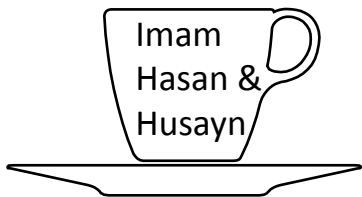
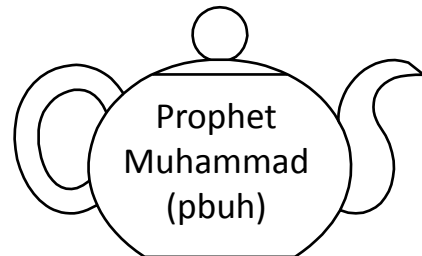
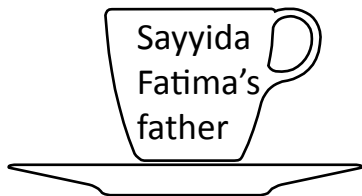
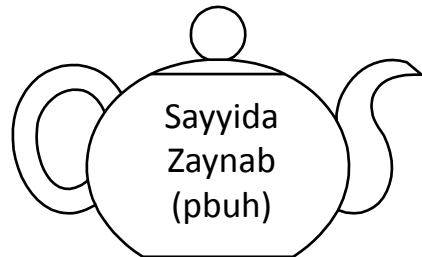
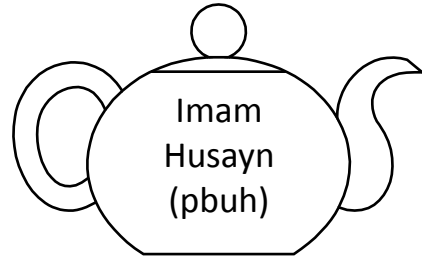
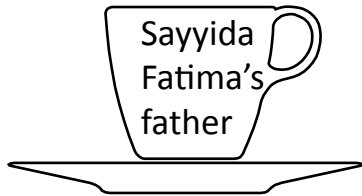

QIYAMA

This means the day of judgement.

We will not and cannot live forever. All of us have heard about someone dying. It is Allah who gives us life and death.

In the Qur'an, Allah says He created life and death to test which of us will do the best of deeds.

“It is He who created death and life, so that He may test which of you does the best of deeds.”

Qur'an – Suratul Mulk – 67:2

By creating death, Allah wants us to compete with each other in doing good deeds.

Islam teaches us to prepare ourselves for the day of judgement. On this day, Allah will bring us back to life.

A recording (like a CD) of our whole life will be shown to us and we will have to explain everything we did.

For the good deeds we will be rewarded and for the bad deeds we will be punished.

The day of qiyama will be a long day. The Qur'an says that one day will be fifty thousand years long and it will be a very hot day. Those who

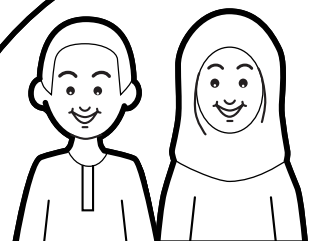

have believed in Allah obeyed Him and done good deeds will have nothing to worry about.

It will be like a report day at school. We will find out how well we did in our lives. If we get our report in our right hand, it means we will go to Janna, but if we get the report in our left hands, then we are in trouble.

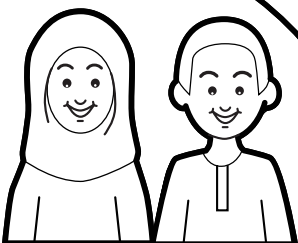

Choices...

Colour the place where you choose to go!

Janna

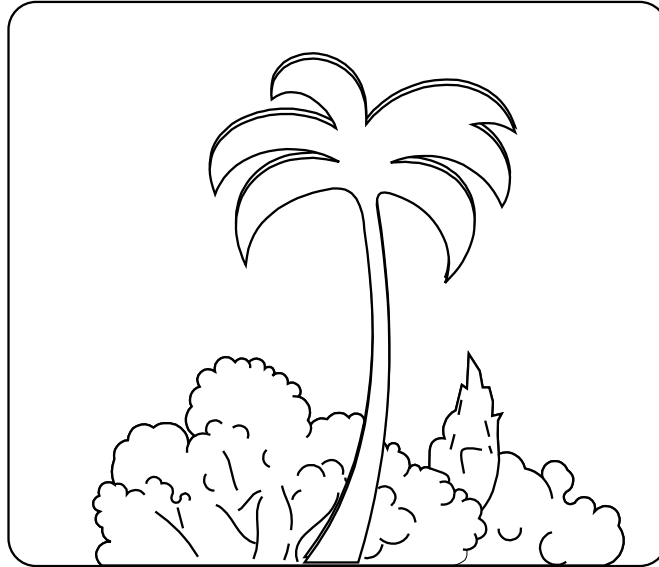

Jahannam

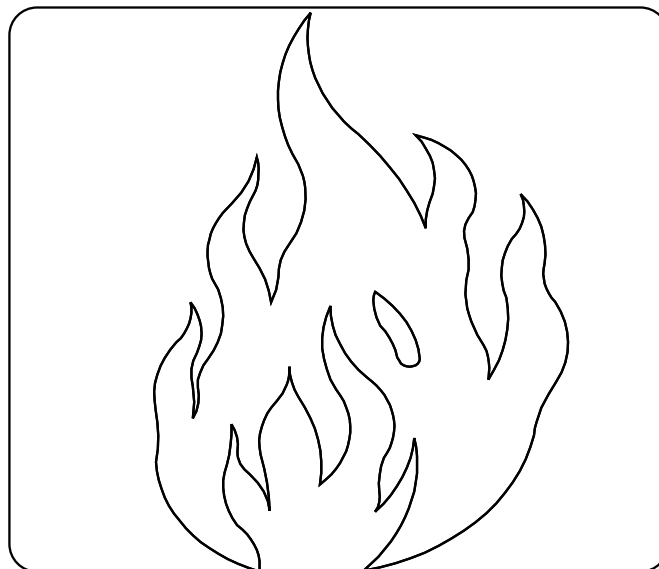

What did Hazrat Hurr choose?

What did he do?

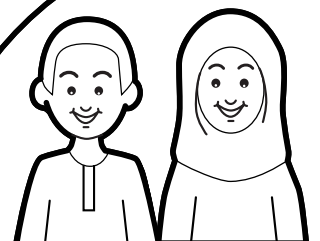

Lillah

When we do anything for Allah; the jaza (reward) is given both in this world and in the hereafter.

Colour the rewards of this world in green and the rewards of the hereafter in yellow.

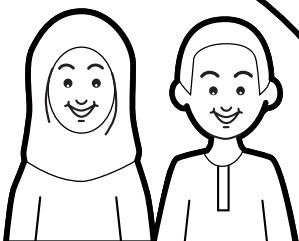
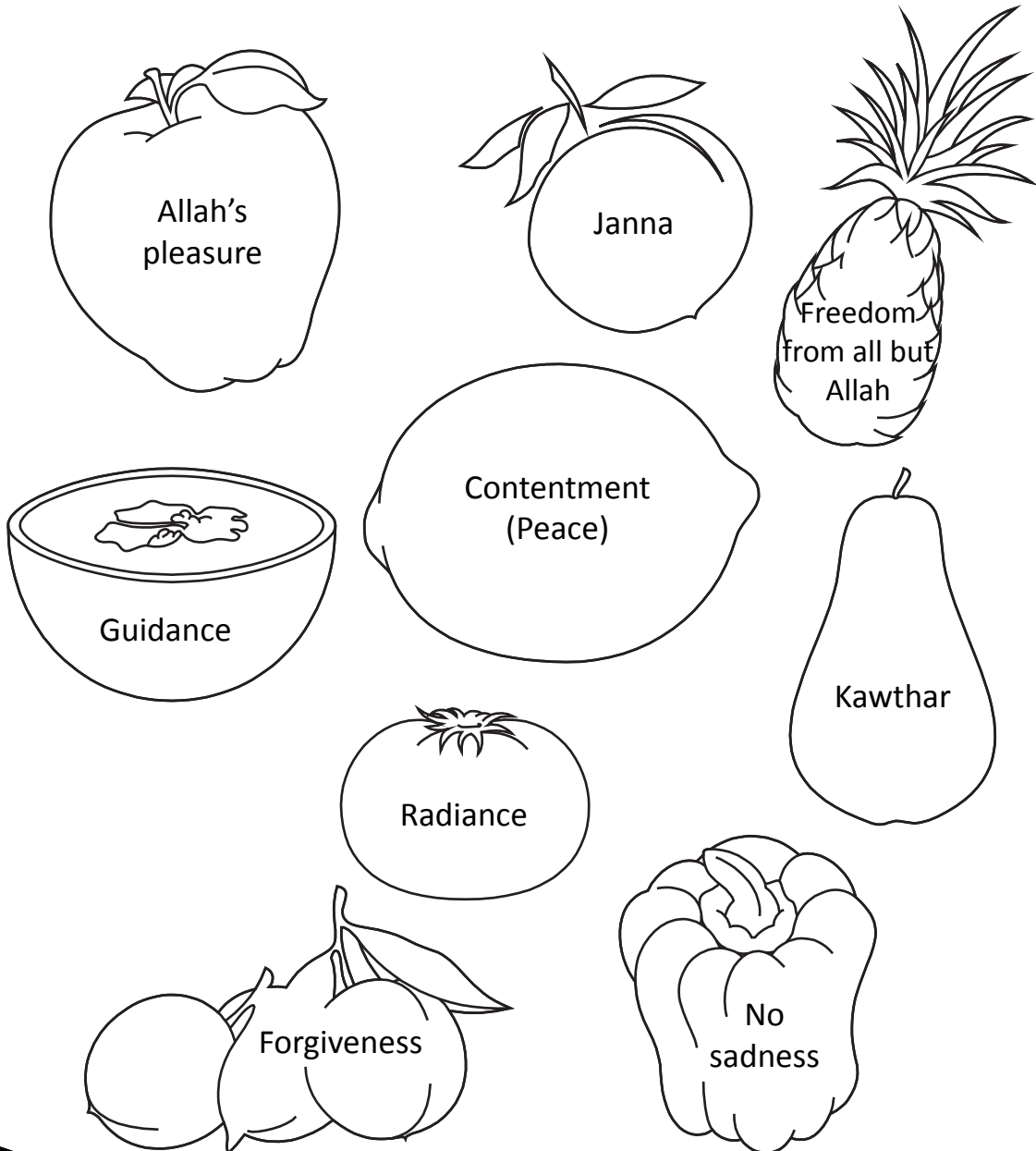

Usul E Deen

What are the 5 usul of deen? (roots of religion)

Put one in each balloon choosing the right answer from the list below:

Nabuwwa, Salaa, Adala, Tawheed, Imama Hajj, Qiyama, Zaka, Jihad

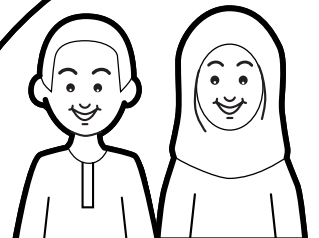
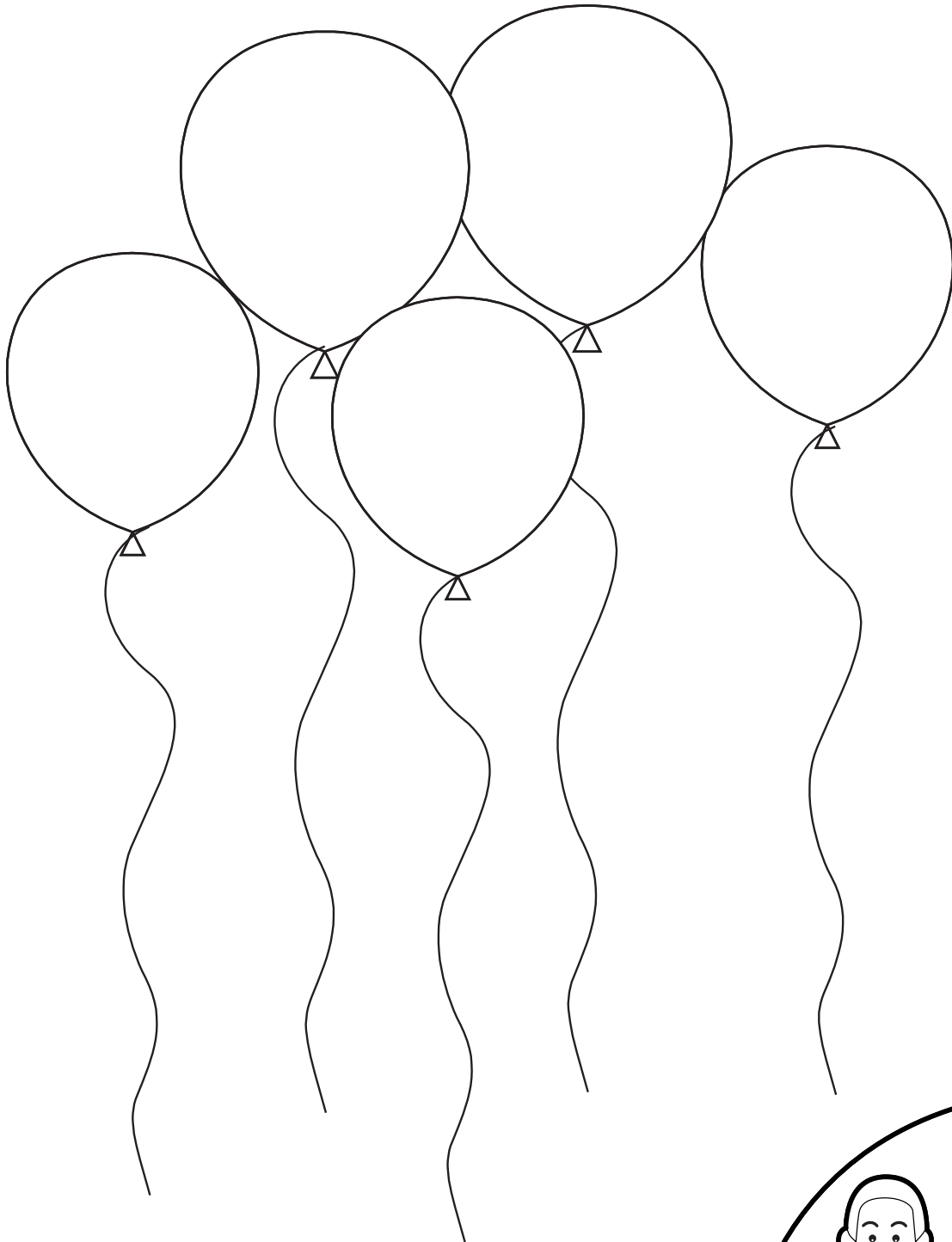

Aqeeda

The word deen (religion) means conduct based upon spiritual ideas which we call aqeeda (belief).

There are five basic roots (usool).

Match the columns

ADALA

PROPHETHOOD

TAWHEED

JUSTICE

IMAMA

ONENESS

NABUWWA

JUDGEMENT DAY

QIYAMA

LEADERSHIP



WORDS USED IN FIQH AND THEIR MEANING- 1

WORD	MEANING	EXAMPLE
Wajib	MUST DO Something that has to be done and not to do it is a sin.	Salaa, Sawm, Khums, Hijab.....
Haram	MUST NOT DO Something that if done is a sin.	Stealing, eating non-halal food, lying.....
Mustahab	BETTER TO DO Something which if done is rewarded. If it is not done there is no sin.	Adhan, Iqama, Salatul Tahajjud (Shab), Reciting Qur'an, Dua...
Makruh	BETTER NOT TO DO Something which is not acceptable but if done is not a sin.	Praying salaa in front of a mirror, picture.... Wearing black shoes.
Jāiz (Mubah)	ALLOWED	All those things that do not fall in the above categories are Jāiz.

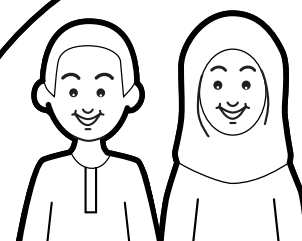

WORD	MEANING	EXAMPLE
Adhãb	PUNISHMENT	Jahannam
Thawãb	REWARD	Janna

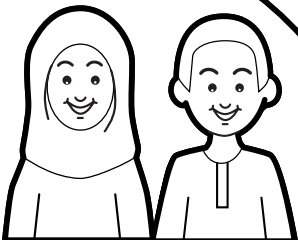

Fiqh Terms

Colour the cars in the colours of the traffic light to which they belong.

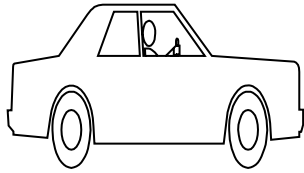

Salaa

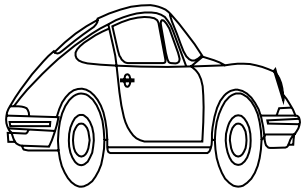

Helping mummy

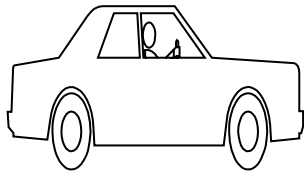

Lying

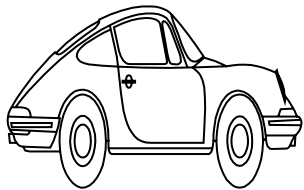

Swearing

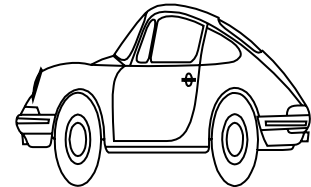
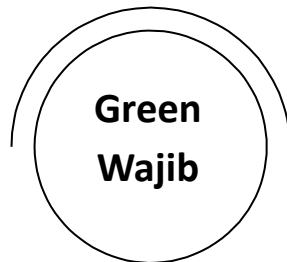
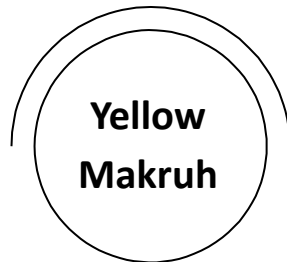
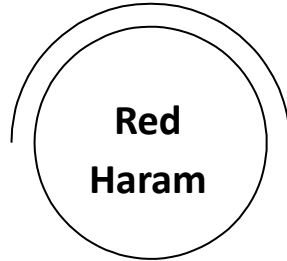

Reciting Qur'an

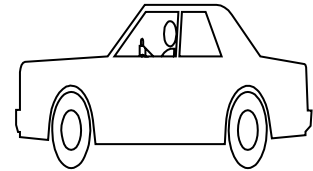

Ghusl of Jumua'

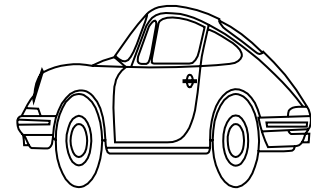

Obeying Allah

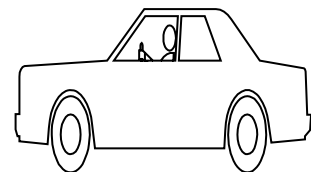

Talking on the toilet

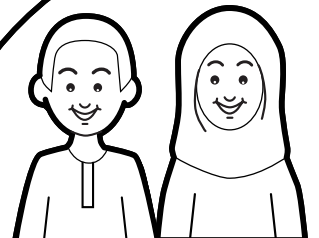

TAQLEED

For every problem in life we go to an expert.

If we are sick, we go to a doctor.

If we want to build a house we go to a builder.

In the same way if we want to know about the rules (masails) of Islam we go to a Mujtahid.

A Mujtahid knows all the Masails. He studies the Qur'an and the Ahadeeth (sayings) of the Ma'sumeen (Ahlul Bayt) and gives Fatawa.

To follow a mujtahid for the masails of Islam is called to do Taqleed.

One who does taqleed is known as a Muqallid.



NAJASAAT

There are 12 main items which are Najis (pl. Najasaat).

Some of the main najasaat are:

Urine (wee wee)

Stool (poo)

Blood

Dog

Pig

Dead Body

Kafir (Unbeliever)

Wine

Beer

Najis does not necessarily mean dirty. A dog may be washed clean but it is still najis. If there is urine on the clothes which have dried, the clothes may look clean but they are still najis.

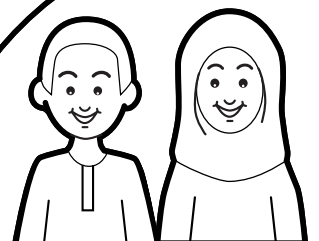

MUTAHHIRAAT

Those things which are najis can also make other things najis. When anything touches a wet najis thing, it too becomes najis.

The items that are able to make a najis thing taahir are known as Mutahhiraat. There are 11 Mutahhiraat. Some of them are:

Water



The Sun



The Earth

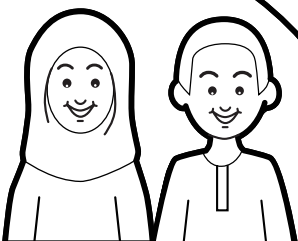

Islam

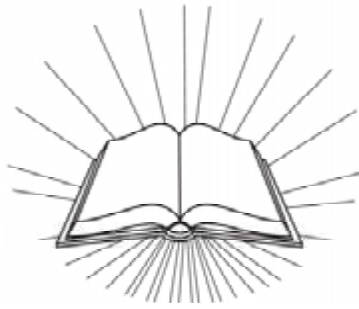

If you cut your knee and the blood touches your clothes, then your clothes become najis. They can only be made taahir by washing them with water.

Similarly, your knee can only become taahir by washing it with water.

When you visit the toilet, you must first remove the najis items and then wash yourself with clean water two times or better still three times to become taahir.

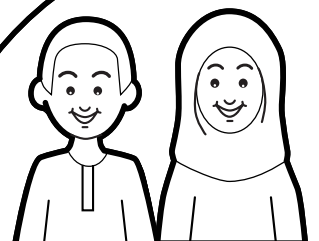

MANNERS AND TAHĀRA IN THE TOILET

1. You must ask permission to use the toilet if it does not belong to you.
2. It is mustahab to wear slippers whilst in the toilet.
3. While in the toilet, must at least be able to cover your private parts from others.
4. It is haram to face qibla or to keep qibla towards the back whilst using the toilet.
5. You must use tãhir water to wash yourself by first removing the najis items and then pouring water at least twice, better still thrice.
6. It is makruh to urinate whilst standing.
7. It is makruh to hold on to one's want to visit the toilet, and if it harms one's health then it is haram.
8. It is mustahab to urinate before salaa and before going to sleep.
9. It is mustahab to enter the toilet with your left foot and come out with your right foot.
10. It is makruh to wash oneself with the right hand.

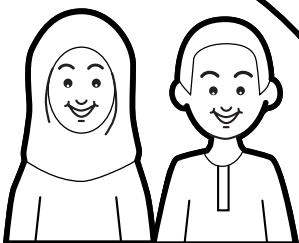

WUDHU

I must do Wudhu before I pray salaa (namaz).

I do Wudhu before I sleep, before I eat, before I go to the mosque or Imambara; in fact I try to be in Wudhu all the time.

When I am angry I do Wudhu. It makes me calm.

This is how I do Wudhu

1. Before I go to the wash basin I roll up my sleeves and take off my socks. If I am wearing a watch, ring, glasses, or hijab I take them off too. If the floor is najis, I wear slippers.
2. At the water tap I first thank Allah for having made the water available and so clean.
(Alhamdulillah) All praise is for Allah.
3. I say my niyya: I am doing Wudhu –
(Qurbatanilallah)
In obedience to Allah and to get closer to Him.

4. I wash my hands twice.



5. I rinse my mouth three times.

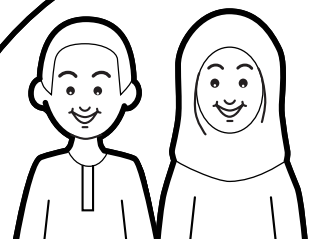

6. I rinse my nose three times.



7. I take some water in my right hand and pour it on my forehead from where the hair grows. I then wipe my face with my hand stretching from thumb to the middle finger. I always wipe downwards from the forehead to the chin. Then I wipe on either side of my face downwards. I make sure that water reaches every part of my face.



8. I take some water in my left hand and pour it just above the right elbow back and front. Then I wipe my right arm with my left hand from the elbow to the fingertips making sure that the water reaches everywhere. Then I take some water in my right hand and wash my left arm in the same way as I washed my right arm.

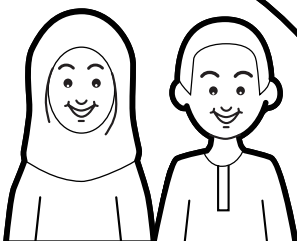

9. With three fingers of my right hand I wipe the middle part of my head with my finger tips making sure that I do not touch my forehead.



10. Then I wipe my right foot with my right hand from the toes to the mound at the joint of the foot and leg. In the same way I wipe my left foot with my left hand.

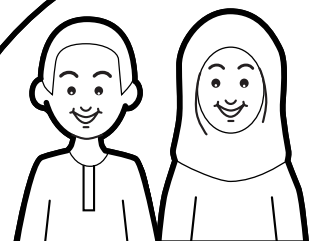

QIBLA

After I have done Wudhu I lay out my musalla and face the Qibla.

Qibla is the direction to the Ka'ba in Makka.

We can find Qibla by:

1. Asking a reliable person.
2. Using a compass.
3. Looking at a mihrab in a masjid. Mihrab is a niche (cut out arch) in the wall which is made in the direction of Ka'ba.
4. By looking at the graves in a Muslim graveyard.

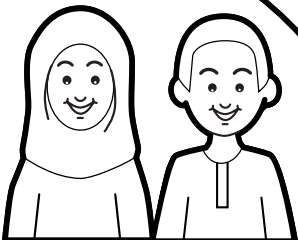

PLACE FOR SALAA

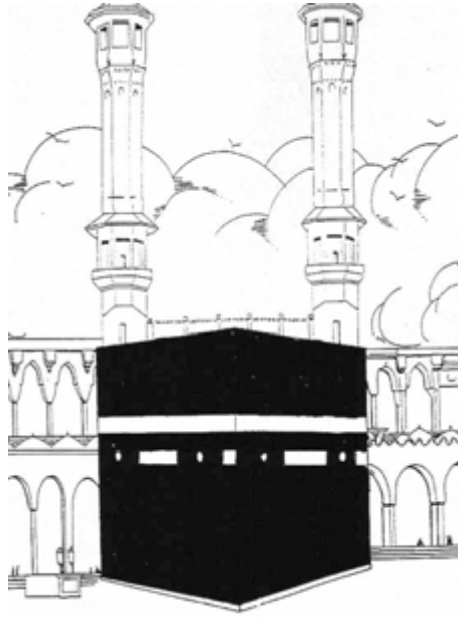

A Muslim can pray where ever he likes as long as he has the permission of the owner of the place.

It is always much better to pray in a **Masjid** - mosque. The thawaabs for praying in a mosque are far greater than praying elsewhere.

The thawaabs for praying one rakaat salaa in **Masjidul Haram** (the sacred mosque of Makka which houses the Ka'ba) is equal to 100,000 rakaats.

The thawaabs for praying one rakaat salaa in **Masjidun Nabi** (the Prophet's mosque) is equal to 10,000 rakaats.

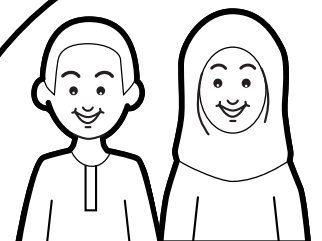

The thawaabs of praying one rakaat salaa in **Masjidul Jamia'** (central mosque of a town) is equal to 100 rakaats.

The thawaabs for praying one rakaat salaa in **Masjidus Suq** (the local mosque in one's area) is equal to 12 rakaats.

For women it is better to pray at home.

It is Makruh to pray:

- a) In a dirty place.
- b) In front of a picture of a human being or animal.
- c) In front of an open Qur'an or any open book.
- d) In front of an open fire or oil lamp.
- e) In front of a person who is facing you.
- f) On a road or a footpath.
- g) In front of a grave or in a cemetery.



CLOTHES FOR SALAA

The clothes for Salaa:

Must be Tāhir.

It must belong to you or you must have the permission of the owner to wear them.

They must not be made from any part of an animal whose meat is Haram to eat.

They must not be made from an animal whose meat is halal to eat but which has not been slaughtered in the Islamic way.*

For boys the clothes must cover their private parts. It is however better to dress fully for salaa.

For boys the clothes must not be made of pure silk or gold (which is haram to wear at all times in any case).

For girls the clothes must cover their whole body except their face, hands upto the wrists, and the feet.

* If the clothes are made of that part of the halal meat animal which has no feeling e.g. hair, teeth, bone, horn and the animal is not slaughtered Islamically then such clothes are allowed in Salaa.

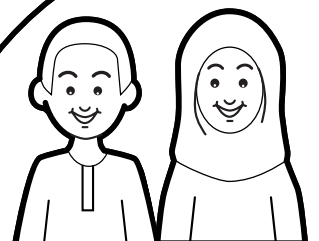

TIMES FOR SALAA



Fajr Salaa

The time for Fajr Salaa is from true dawn (subh sadiq) upto sunrise.

The best time (fadhila) for praying Salaatul Fajr is from subh sadiq upto the appearance of reddish streaks on the horizon (before sunrise).

Dhuhr Salaa

The time for Dhuhr Salaa is from Mid Day upto a few minutes before sunset.

The best time (fadhila) for praying Salaatul Dhuhr is from Mid Day upto the time when the shadow of a thing e.g. a stick becomes equal to it's length.

Mid Day is half way between Sunrise and Sunset. It's time varies throughout the year.

'Asr Salaa

The time for 'Asr Salaa is from a few minutes after Mid Day upto sunset.

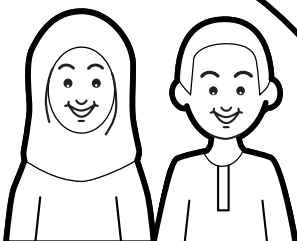

The best time (fadhila) for praying Salatul 'Asr is from a few minutes after Mid Day upto the time when the shadow of a thing becomes double it's length.

Maghrib Salaa

The time for Maghrib Salaa is from after sunset upto a few minutes before midnight - 12 hours after Dhuhr time.

The best time (fadhila) for praying Salaatul Maghrib is from after sunset upto the time when the reddish streaks in the horizon vanish.

Eisha Salaa

The time for praying Eisha salaa is from a few minutes after sunset upto midnight - 12 hours after Dhuhr time.

The best time (fadhila) to pray Salaatul Eisha is from a few minutes after sunset upto the third of the night. e.g. if midnight was 12.01 a.m. and Maghrib was 9.01 p.m. then a third would be upto 10.01 p.m.

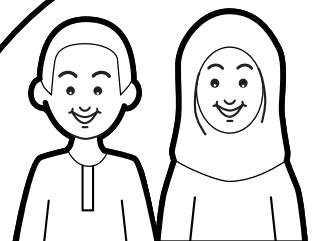

SALAA

الْحَمْدُ لِلَّهِ رَبِّ الْعَالَمِينَ

All praise is for Allah, the Lord of the worlds.

Allah made me and looks after me. He knows when I am happy and when I am sad. He knows when I am good and when I am naughty. He has given me everything. I love Allah.

Allah loves me too and He wants to talk to me. That is why He sent us the Qur'an, the Prophets and the Ma'sumeen.

But Allah wants me to talk to Him too so in the Qur'an and through Prophet Muhammad (pbuh) and his AhlulBayt He has taught me how to pray salaa. Salaa is talking to Allah.

I can talk to Allah anywhere about anything. He always hears and understands. He hears me if I whisper or if I shout or even if I think of something in my mind.

However, when I stand for salaa I pray the way He wants me to because I love Him and I want to do what He says.

اللَّهُ أَكْبَرُ Allah is Greater than anything and/or anyone.

He has made me so He knows what is right for me and what is wrong for me. Allah wants me to talk to Him through salaa.



Some prayers are longer than others but I just love talking to Allah.

Allah wants me to pray with other people as well. The Prophet (pbuh) has said that salaa has greater power when we pray together in Jama'a. I try to pray my salaa in Jama'a as much as possible.

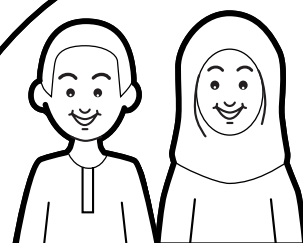

My actions of Salaa

These are the actions that I have to know before I pray salaa. They all have special names.

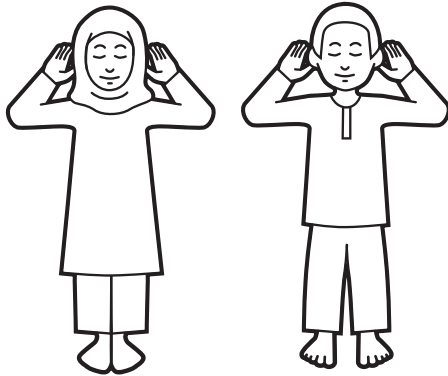

Takbeeratul Ihram

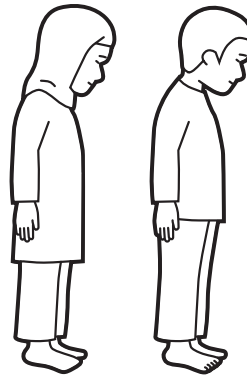

Qiyam

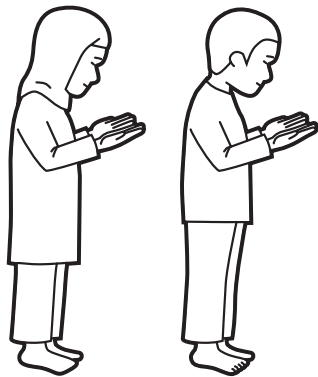

Qunoot

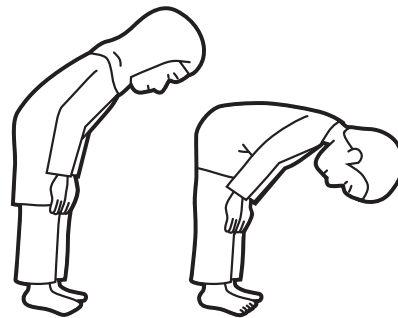

Rukoo

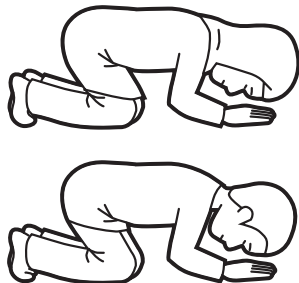

Sajda

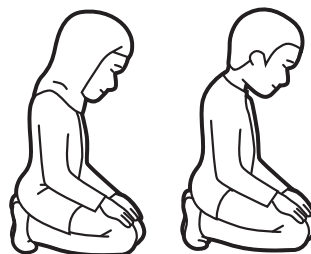

Julooos

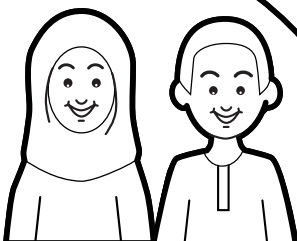

Salaa

Match the columns below:

	No. of Rakats
Maghrib Salaa	4
Asr Salaa	3
Fajr Salaa	4
Eisha Salaa	2
Dhuhr Salaa	4

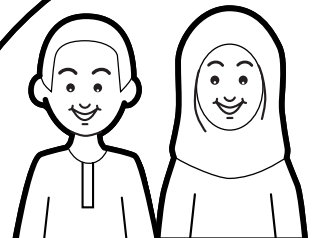

ADHAN

Adhan is the call for salaa (prayer). It is called in a loud voice. It can be called from the minaret of a masjid (mosque) or from where ever I pray. I always begin my salaa with adhan and iqama. After I have done Wudhu, I stand on my musalla facing the qibla. With the palms of my hand facing qibla and my thumbs just under my ears I recite;

4 times Allahu Akber

اللَّهُ أَكْبَرُ

2 times Ash hadu anl laa ilaaha illallah

أَشْهَدُ أَنْ لَا إِلَهَ إِلَّا اللَّهُ

2 times Ash hadu anna Muhammadar rasulullah

أَشْهَدُ أَنَّ مُحَمَّدًا رَسُولُ اللَّهِ

2 times Ash hadu anna Aliyyuw waliyullah

أَشْهَدُ أَنَّ عَلِيًّا وَليُّ اللَّهِ

2 times Hayya alas salaa

حَيَّ عَلَى الصَّلَاةِ

2 times Hayya alal falaah

حَيَّ عَلَى الْفَلَاحِ

2 times Hayya alaa khayril 'amal

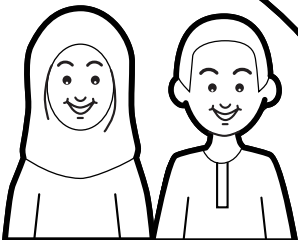

حَيَّ عَلَى خَيْرِ الْعَمَلِ

2 times Allahu Akber with my palms facing qibla and thumbs under my ears

اللَّهُ أَكْبَرُ

2 times Laa ilaaha illallah

لَا إِلَهَ إِلَّا اللَّهُ

If someone else is reciting Adhan loudly, I sit with respect and follow the recitations, reciting salawat after the names of the Prophet (pbuh) and Imam Ali (pbuh)

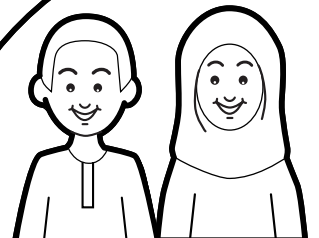
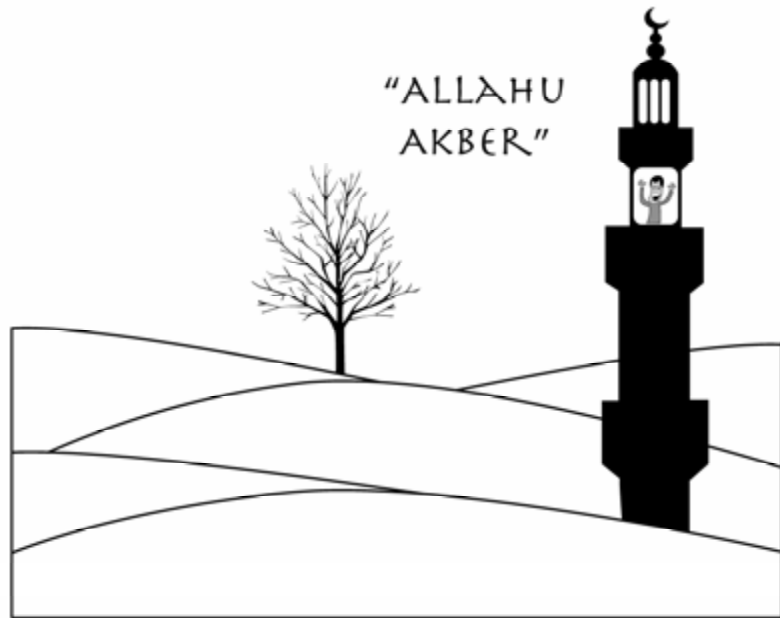

IQAMA

Iqama is the call to start salaa. It is said just before salaa.

With my palms facing qibla and my thumbs just under my ears, I recite:

2 times Allahu Akber

اللَّهُ أَكْبَرُ

2 times Ash hadu anl laa ilaaha illallah

أَشْهَدُ أَنْ لَا إِلَهَ إِلَّا اللَّهُ

2 times Ash hadu anna Muhammadar rasulullah

أَشْهَدُ أَنَّ مُحَمَّدًا رَسُولُ اللَّهِ

2 times Ash hadu anna Aliyyuw waliyullah

أَشْهَدُ أَنَّ عَلِيًّا وَليُّ اللَّهِ

2 times Hayya alas salaa

حَيَّ عَلَى الصَّلَاةِ

2 times Hayya alal falaah

حَيَّ عَلَى الْفَلَاحِ

2 times Hayya alaa khayril 'amal

حَيَّ عَلَى خَيْرِ الْعَمَلِ

2 times Qad qaamatis salaa

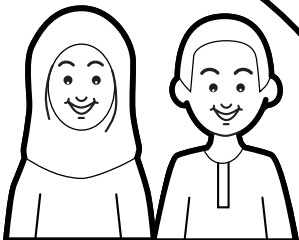

قَدْ قَامَتِ الصَّلَاةُ

2 times Allahu Akber with my palms facing qibla and thumbs under my ears

اللَّهُ أَكْبَرُ

Once Laa ilaaha illallah

لَا إِلَهَ إِلَّا اللَّهُ

After the iqama, I begin my salaa

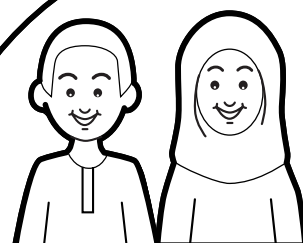

Adhan

Colour the balloons which we should be thinking about when we recite 'Hayya alal falaah'- Hurry to success.

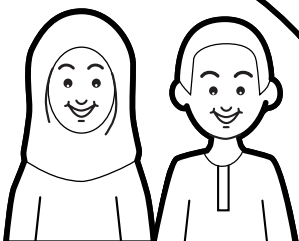
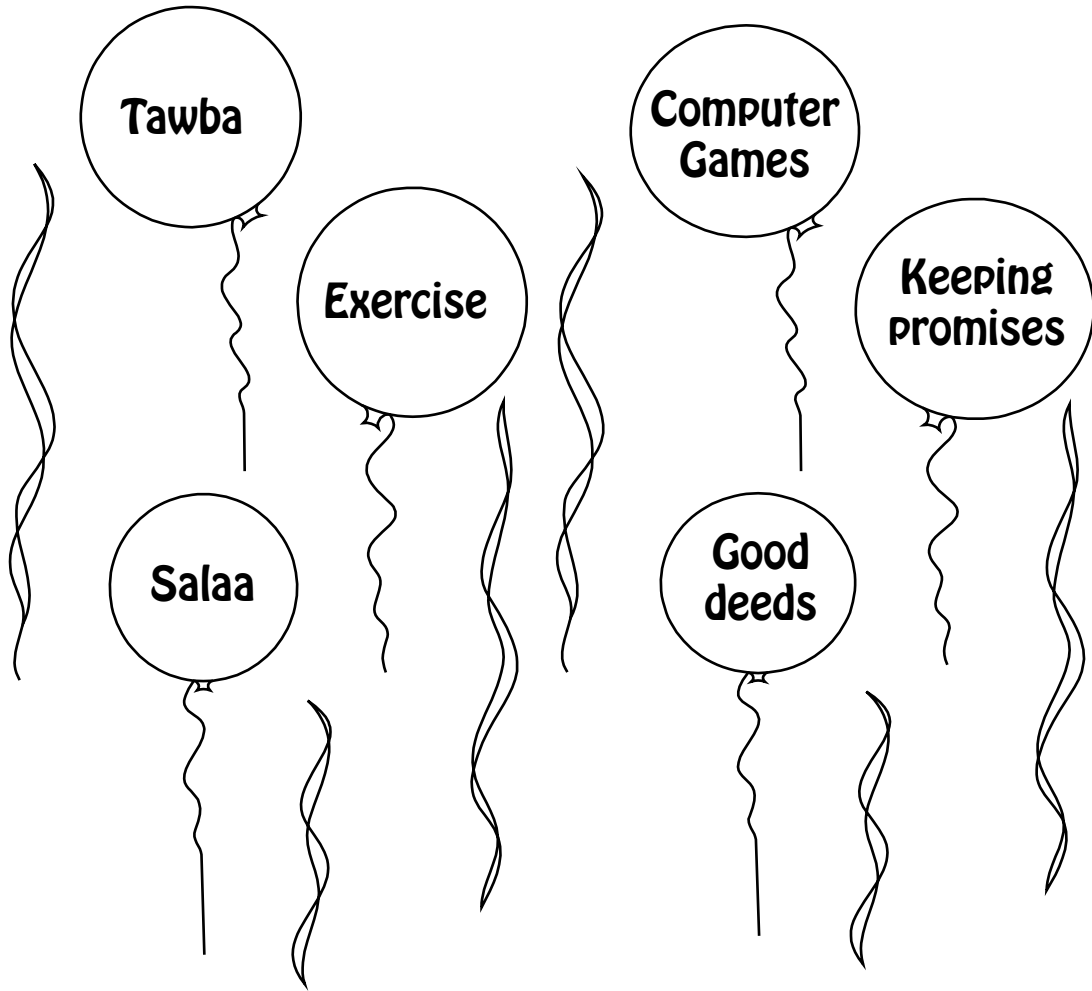

THE FIRST MU'ADHIN

The Prophet (Pbuh) was looking for a way to announce the time of Salaa. After the masjid in Madina was built, people came to pray Salatul Jama'a regularly but were often late. To be able to find out the time for salaa they had to look at the sun. There were no clocks or watches at that time.

Lots of different ideas were put forward. Some people suggested a trumpet, some a bell.... The Prophet (Pbuh) did not like any of these ideas.

It was then that Jibrail came down with the Adhan chosen by Allah for the announcement for Salaa.

The Prophet (Pbuh) taught the Adhan to Imam Ali (Pbuh) and told him to teach it to Bilal.

Bilal was appointed for the duty of calling the Adhan. He had a loud clear voice.

Bilal was therefore the first Mu'adhin of Islam. A Mu'adhin is one who calls out Adhan. When Adhan is called, it is Mustahab to repeat each sentence after the Muadhin.

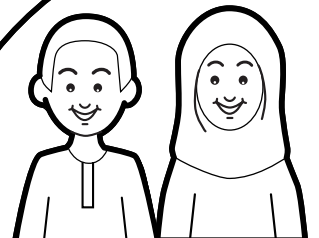

Actions of Salaa

Number the actions of salaa in their correct order (tarteeb).

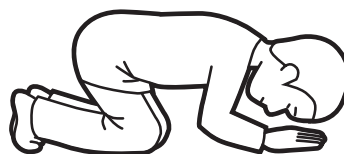
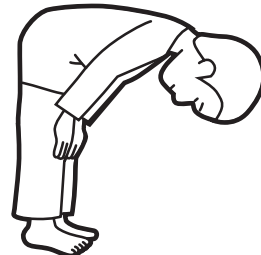
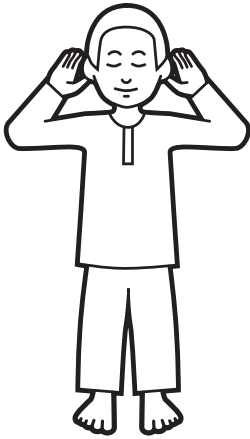

Sajda

Label and colour in the seven parts which must touch the ground during Sajda:

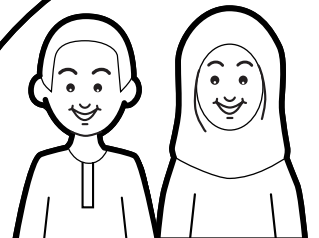
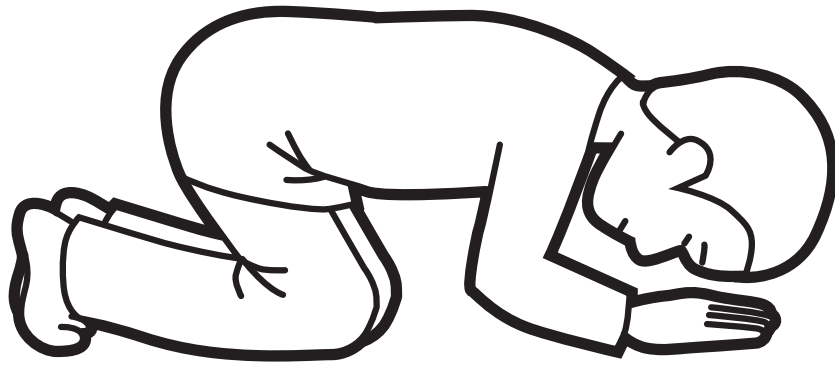

Jigsaw

Fill in the missing word to find the name of the perfect person.

ISLA_

Q_R'AN

A_LULBAYT

SAL_A

EXA_PLE

_ADINA

_LLAH

HA_ITH

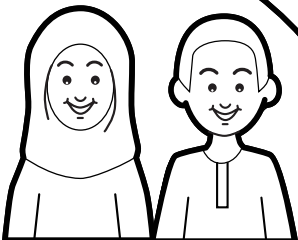

NUMBER OF RAKAATS AND TIMES OF SALAA (Namaz)

I pray five Salawat (plural of salaa) three times a day. Each salaa is divided into rakaats. In each rakaat, I do qiyam, rukoo, two sajadaat and juloos.

1. Fajr Salaa – Early in the morning just as the night ends, I pray 2 rakaats.
2. Dhuhhr and ‘Asr salaa – At midday (halfway through the day), I pray Dhuhhr followed by ‘Asr salaa.
4 rakaats for Dhuhhr and 4 rakaats for ‘Asr.
3. Maghrib and Eisha salaa – Just as the day ends and the night begins, I pray Maghrib followed by Eisha salaa.
3 rakaats for Maghrib and 4 rakaats for Eisha.

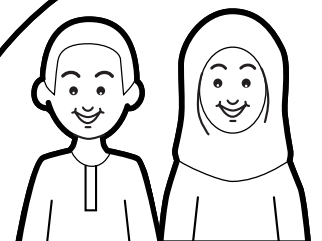

THIS IS HOW I PRAY SALAA (NAMAZ)

I say my niyya. For example, if I am praying Maghrib salaa, I say: "I am praying 3 rakaats for Salaatul Maghrib –

Qurbatan ilallah – قُرْبَةً إِلَى اللَّهِ

(To obey Allah and to get closer to Him).

I raise my hands up to my ears for takbeeratul ihram, and I say takbeer: "Allahu Akber اللهُ أَكْبَرُ

(Allah is Greater than anything and anyone).

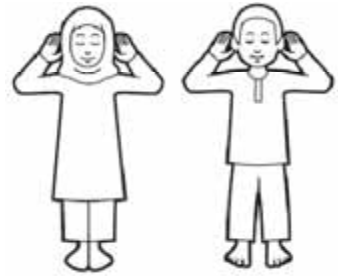

Now I stand still for qiyam and looking at the ground (mohr, turbat). I recite **Suratul Fatiha** and **one other sura** from the Qur'an.

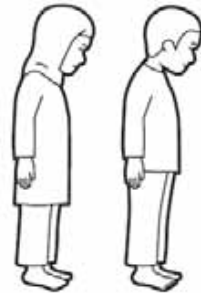

I then say "Allahu Akber" and then go to rukoo and looking between my feet, I recite:

"Subhana rabbiyal 'adheemi wa bihamdih

سُبْحَانَ رَبِّيَ الْعَظِيمِ وَ بِحَمْدِهِ

(Glory be to my Rabb, the Great and praise be to Him).

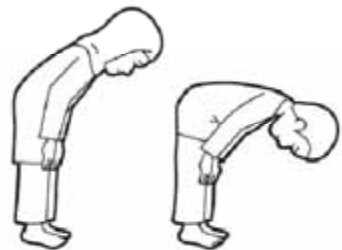

I stand up from rukoo for qiyam and I recite: “Samia’llahu liman hamida

سَمِعَ اللَّهُ لِمَنْ حَمِدَهُ

(Allah hears he/she who praises Him).

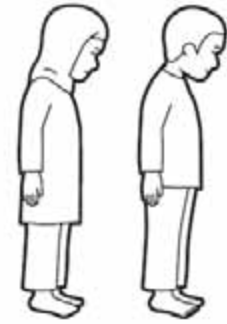

I then say “Allahu Akber” and then go to sijda making sure that the seven parts of my body touch the ground – My forehead, two palms, two knees, and the two tips of my toes.

In sijda, I recite:

“Subhana rabbiyal ‘alaa wa bihamdi

سُبْحَانَ رَبِّيَ الْأَعْلَى وَ بِحَمْدِهِ

(Glory be to my Rabb, the most High and praise be to Him).



I sit up from sijda for juloos with my legs tucked under me and looking at my lap, I say:

“Astaghfirullah rabbiy wa atubu ilayh

أَسْتَغْفِرُ اللَّهَ رَبِّي وَ أَتُوبُ إِلَيْهِ

(I see forgiveness from Allah, my Rabb, and I turn repentant to Him)

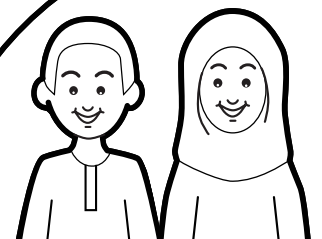

I go back to sijda once more and I recite:

“Subhana rabbiyal ‘alaa wa bihamdi

سُبْحَانَ رَبِّيَ الْأَعْلَىٰ وَ بِحَمْدِهِ

(Glory be to my Rabb, the most High and praise be to Him).



I sit up from sijda for juloos and recite:

“Allahu Akber - اللَّهُ أَكْبَرُ

(Allah is Greater than anything and anyone)



Now I stand up for qiyam of the second rakaat.

Whilst in the process of standing up, I recite:

“Bihawlillahi wa quwwatihi aqumu wa aq’ud

بِحَوْلِ اللَّهِ وَ قُوَّتِهِ أَقُومُ وَ أَقْعُدُ

(With the power and strength of Allah, I stand and sit).

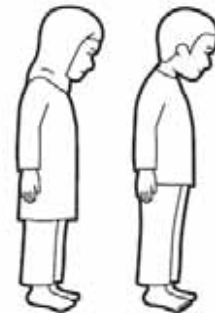

I stand for qiyam and recite Suratul Fatiha and Suratul Ikhlas.

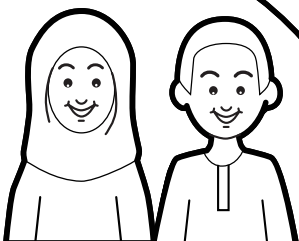

I raise my hands for qunoot and recite:

“Rabbanaa aatinaa fid dunya hasanataw wa fil aakhirati hasanataw waqinaa adhaaban naar. Allahumma salli ‘alaa Muhammadiw wa aali Muhammad



رَبَّنَا آتِنَا فِي الدُّنْيَا حَسَنَةً وَفِي الْآخِرَةِ حَسَنَةً وَقِنَا عَذَابَ

النَّارِ

(Our Rabb. Grant us good in this world and good in the hereafter, and save us from the punishment of the fire)

اللَّهُمَّ صَلِّ عَلَى مُحَمَّدٍ وَآلِ مُحَمَّدٍ

I then do rukoo and the two sajadaat (sijda’s) just like the first raka’at.

When I sit for juloos after the second sijda, I say Takbeer “Allahu Akber” and then recite Tashahhud:

“Ash hadu anl laa ilaaha illallahu wahdahu laa sharika lah, wa ash hadu anna Muhammadan ‘abdahu wa rasuluh, Allahumma salli ‘alaa Muhammadiw wa aali Muhammad

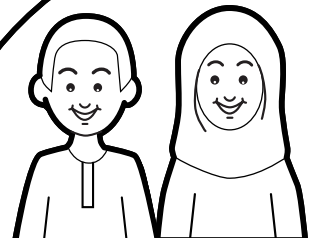

أَشْهَدُ أَنْ لَا إِلَهَ إِلَّا اللَّهُ وَحْدَهُ لَا شَرِيكَ لَهُ

وَ أَشْهَدُ أَنَّ مُحَمَّدًا عَبْدُهُ وَ رَسُولُهُ

اللَّهُمَّ صَلِّ عَلَى مُحَمَّدٍ وَ آلِ مُحَمَّدٍ

(I bear witness that there is no god except Allah, the only One and there is no partner for Him, and I bear witness that Muhammad is His slave and His messenger. O Allah! Send blessings on Muhammad and his ahlulbayt).

After the tashahhud, I stand up for qiyam for the third raka't. In the process of standing, I recite: "Bihawlillahi wa quwwatihi aqumu wa aq'ud - بِحَوْلِ اللَّهِ وَ قُوَّتِهِ أَقُومُ وَ أَقْعُدُ - (With the power and strength of Allah, I stand and sit).

In qiyam of the third raka't, I recite tasbihaat e arba'a three times: "Subhaanallahi walhamdu lillahi wa laa ilaaha illallahu wallahu akber - سُبْحَانَ اللَّهِ وَ الْحَمْدُ لِلَّهِ وَ لَا إِلَهَ إِلَّا اللَّهُ وَ اللَّهُ أَكْبَرُ (Glory be to Allah, and all praise is for Allah, and there is no god except Allah, and Allah is greater than everything and everyone).

I finish my third and final raka't of Salaatul Maghrib with rukoo, qiyam, the two sajadaat; and in the last juloos, I say Takbeer – "Allahu Akber" and then I recite Tashahhud and Salaam: "Ash hadu anl laa ilaaha illallahu wahdahu laa sharika lah, wa ash hadu anna Muhammadan 'abdahu wa rasuluh, Allahumma salli 'alaa Muhammadiw wa aali Muhammad –

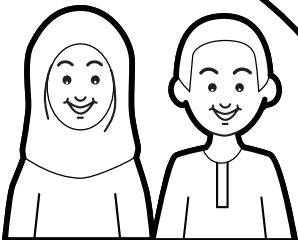

أَشْهَدُ أَنْ لَا إِلَهَ إِلَّا اللَّهُ وَحْدَهُ لَا شَرِيكَ لَهُ
وَ أَشْهَدُ أَنَّ مُحَمَّدًا عَبْدُهُ وَ رَسُولُهُ
اللَّهُمَّ صَلِّ عَلَى مُحَمَّدٍ وَ آلِ مُحَمَّدٍ

(I bear witness that there is no god except Allah, the only One and there is no partner for Him, and I bear witness that Muhammad is His slave and His messenger. O Allah! Send blessings on Muhammad and his ahlulbayt).

“Assalamu ‘alayka ayyuhan nabiyyu wa rahmatullahi wa barakatuh; Assalamu ‘alaynaa wa ‘alaa ibadullahis saaliheen; Assalamu ‘alaykum wa rahmatullahi wa barakatuh -

السَّلَامُ عَلَيْكَ أَيُّهَا النَّبِيُّ وَ رَحْمَةُ اللَّهِ وَ بَرَكَاتُهُ
السَّلَامُ عَلَيْنَا وَ عَلَى عِبَادِ اللَّهِ الصَّالِحِينَ
السَّلَامُ عَلَيْكُمْ وَ رَحْمَةُ اللَّهِ وَ بَرَكَاتُهُ

(Salaams be upon you, O Prophet and the mercy of Allah and His blessings; Salaams be upon us and upon all the righteous servants of Allah; Salaams be upon you all and the mercy of Allah and His blessings).

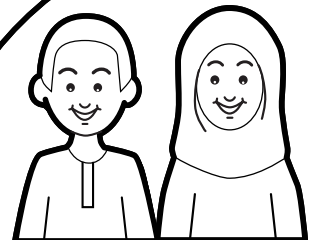

QUNOOT

Qunoot means to be humble when praying to Allah.

In salaa it refers to when I raise my hands for dua to Allah in the second rakaat just before I go to ruku'.

Allah loves listening to my dua.

Before I raise my hands for Qunoot I say **اللَّهُ أَكْبَرُ**

I raise my hands keeping them together just below my face with the fingers together and thumbs apart. I am asking from Allah humbly.

I recite my dua loudly. These are some of the duas that I recite. Allah has taught them to us. They are all found in the Qur'an.

رَبَّنَا آتِنَا فِي الدُّنْيَا حَسَنَةً وَفِي الْآخِرَةِ حَسَنَةً وَقِنَا عَذَابَ النَّارِ

"Our Lord! Give us good in this world and good in the hereafter, and save us from the punishment of the fire."

Qur'an - Suratul Baqara 2:201

رَبِّ أَرْحَمُهُمَا كَمَا رَبَّيْنِي صَغِيرًا ط

"Lord! Have mercy on them (my parents) just as they had mercy on me when I was little..."

Qur'an - Suratu Bani Israil 17:24

رَبِّ زِدْنِي عِلْمًا

"Lord! Increase my knowledge.."

Qur'an - Suratu Taha 20:114

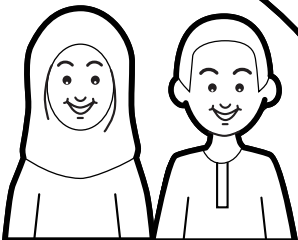

رَبَّنَا اغْفِرْ لِي وَلِوَالِدَيَّ وَلِلْمُؤْمِنِينَ يَوْمَ يَقُومُ الْحِسَابُ

"Our Lord! Forgive me, my parents and the believers on the day of accounting"

Qur'an - Suratu Ibrahim 14:41

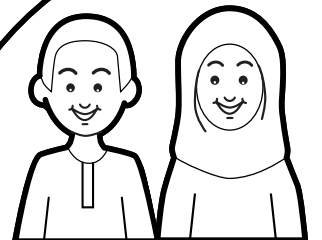

TA'QIBAAT

Ta'qibaat means the tasbeeh and duas that follow salaa.

After I have finished my salaa I first recite 'Allahu Akber'

اللَّهُ أَكْبَرُ three times.

Then I recite Salawat - اللَّهُمَّ صَلِّ عَلَى مُحَمَّدٍ وَآلِ مُحَمَّدٍ

After Salawat I recite the tasbeeh of Sayyida Fatima Zahra (pbuh)

34 times اللَّهُ أَكْبَرُ

33 times الْحَمْدُ لِلَّهِ

33 times سُبْحَانَ اللَّهِ

After the tasbeeh I recite a sura from the Qur'an and then one of the recommended duas. I then go into sijda to thank Allah for everything and to ask for forgiveness.

In sijda I recite the following as many times as I can

شُكْرًا ، شُكْرًا ، شُكْرًا لِلَّهِ

Thank you, Allah

عَفْوًا ، عَفْوًا ، عَفْوًا

Forgive me

Finally, I get up and face qibla to recite the ziyara of the ma'sumeen.

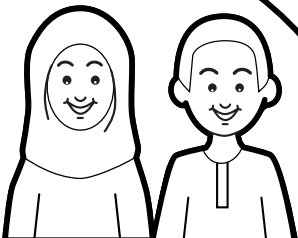

REMEMBERING ALLAH ALL THE TIME

Before I do anything I recite:
Bismillahir rahmaanir raheem

بِسْمِ اللَّهِ الرَّحْمَنِ الرَّحِيمِ

(I begin) in the name of Allah, the Kind, the Merciful
In every situation - happy or sad I recite:

Alhamdu lillah

الْحَمْدُ لِلَّهِ

All praise is for Allah

When I thank someone I say:

Jazakumulllah

جَزَاكُمُ اللَّهُ

May Allah reward you.

Whenever I decide to do something I say:

Insha'Allah

إِنْ شَاءَ اللَّهُ

If Allah wishes.

When I am parting from someone I say:

Fiamanillah

فِي أَمَانِ اللَّهِ

(I leave you) in the care of Allah.

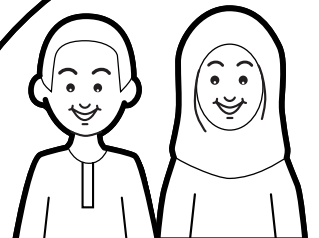

INSHA ALLAH!

One day Imam Ali (pbuh) was carrying a heavy bag filled with date seeds.

He was asked "What are you carrying in this heavy bag?"

Imam Ali (pbuh) replied "A few date palms, Insha Allah."

Since Imam Ali (pbuh) had faith in Allah and worked for none but Allah, he knew that if Allah willed the date seeds would soon become trees.

Sure enough after he had planted them and looked after them they started growing to become trees that would feed others.

With faith in Allah and hard work, everything is possible.

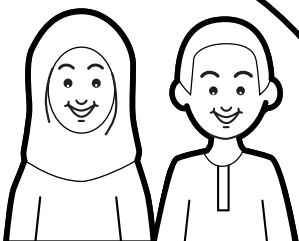

I AM GOING TO BUY A COW

Ahmed was so happy! He had saved enough money to buy a cow of his own. Now he could have fresh milk every day.

He set off to go to the market near his town to buy the cow. On the way he met his friend Burayr.

"Assalamu Alaykum O Ahmed" said Burayr

"Alaykumus Salaam " replied Ahmed.

"Where are you going?" Burayr asked.

"I am going to the market to buy a cow" Ahmed said, his voice full of joy.

"You must always say "Insha Allah (If Allah wishes)" Burayr told him.

Ahmed did not think he had to say 'Insha Allah' because he had the money and he was on his way to the market. Of course he would buy the cow!!!

He went on his way.

Just before he got to the market a robber stopped him, and took all his money away.

Ahmed was very sad. He turned to go back home when he met Burayr again.

"Where is the cow?" asked Burayr.

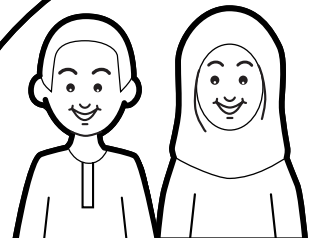

Ahmed replied " Insha Allah on the way to the market, a robber caught me, Insha Allah he emptied my pockets, and Insha Allah he took my money".

Burayr looked at him in amazement and told him that he was saying Insha Allah at the wrong places; he should have said it at the outset when he went to buy the cow.

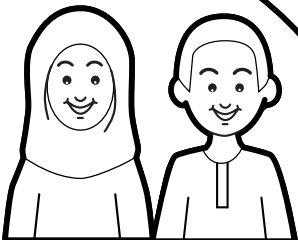

LYING

"A liar does not lie, except when he feels lower within himself/herself."

Prophet Muhammad (pbuh)

Lies can be small and light natured like in jokes or serious with an aim to mislead someone. Be it small or big, light-hearted or in the form of a joke, it is still hated.

Imam Ali Zaynul Aabideen (pbuh) has said:

"Keep away from lies, be it small or big, whether in a serious way or not, or by way of a joke. For everyone who tells small lies will also dare to speak big lies." One lie leads to another and soon it becomes a habit.

Lying leads to disgrace and is the key to conflict in the home and society.

It leads to false swearing and more sins.

The best way to remove the habit of lying is to study history and look at the ends of those who lied. E.g. Abu Lahab, Abu Sufyan, Muawiya, Yazid...

They rejected the truth and lied.

In the Qur'an Allah says:

"Indeed there have been examples before you, so travel on the earth and see what was the end of those who lied."

Qur'an - Suratu Aali Imran 3:136

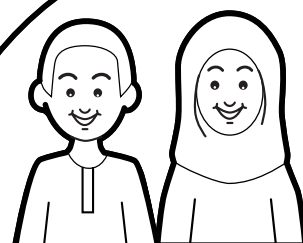

A BIG PURPLE DOG!

Anwar and Salma were playing with a ball in the sitting room when it crashed into mum's favourite vase.

The vase came crashing down on the floor shattering it to pieces.

Anwar looked worried: "Mum's going to be furious! Daddy gave her that vase for her birthday"

Salma said: "She told us not to play with a ball in the house!"

Just then mum walked in! She took one look at the vase and sat down looking really sad.

Both Anwar and Salma said:

"Mum! It was'nt us but a...

Anwar said, "A big dog ran in....

Salma said "A purple...

Both continued looking at each other "A big purple dog ran in and knocked it over!"

Mum looked at them both without saying anything. Her eyes said it all.

After a long pause, she said:

" I am not sad because you broke the vase but I am sad at two things: You both disobeyed me when I had told you not to play with a ball in the house and you lied to me."

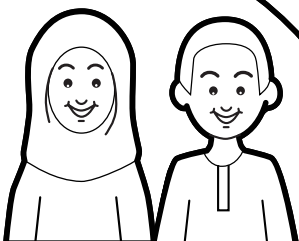

Anwar and Salma apologised and promised to try their best never to disobey or lie to her.

"You are forgetting one thing" Mum said.

"Who is going to tidy up the mess!!!!"

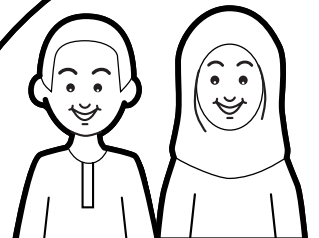

LESS WANTING

The Prophet (pbuh) has said:

"Allah has said:

...When my slave prefers his/her desire over My wish, I put his/her affairs into confusion, make his/her life confused in the world and his/her heart pre-occupied with the world.....

If my slave prefers My wish over his/her desire, angels protect him/her, the earth guarantees his/her sustenance and I look after his/her affairs and bring the world to him/her although it may be reluctant to do so...."

It is said that the renowned Muslim scholar Abu Sina (Avicenna) once looked with scorn (in a bad way) at a poor man eating left over leaves from a grocer's shop.

The man greeted him and told him:

"What is the contempt for? You are the slave of my slaves!!"

Abu Sina could not understand what the man was saying. The poor man explained:

"O Abu Sina! You are the slave of your desires (want of good food) whilst desires are my slaves. Therefore you are the slave of my slaves."

Abu Sina realised the wisdom of the poor man's words.

The person who is desirous (wants more all the time) is always busy in anxiety, worry and sorrow for he/she feels that whatever he/she has got is just not enough.



MANNERS OF TALKING

The following were guidelines given by Imam Husayn (pbuh) to Ibn Abbas about good and useful conversation.

"Do not begin a conversation without first greeting the person you are talking to."

"Keep away from a conversation which is without an aim or object for it lowers your position."

"...Wait to speak at the right opportunity; many speak the truth but not at the right time and therefore have to face disrespect."

"Do not argue with a patient person for he will win with the power of his patience."

"Do not argue with foolish and ignorant people as they will hurt you with their nonsense."

"You may only do that gheebat (backbiting) of a person which you would like him to speak of you."

We might know that it is polite to speak softly and clearly but we must also speak the truth and that which is useful.

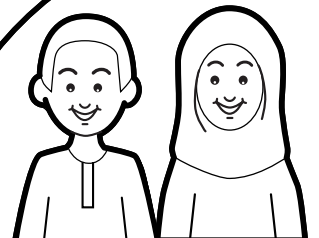

Before you speak always take the mouth test:

1. Is it the truth?
2. Is it useful?
3. Is it hurtful?
4. Is Allah going to be pleased with those words?

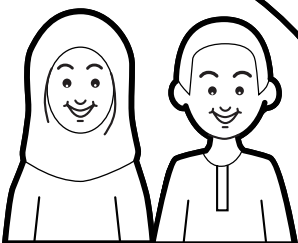

ANGER

In describing those who will go to Janna, Allah says in the Qur'an:
"And that who swallow their anger and forgive people; and Allah loves those who do well (to others)."
Suratu Ali Imran 3:134

When someone hurts our feelings without it being our fault it makes us angry and sometimes we say and do things which we regret later.

Imam Ali (pbuh) has said that when you get angry, you must first sit down if you are standing and lie down if you are sitting.
Take ten deep breaths and go and do Wudhu, for the Prophet (pbuh) has said: 'Indeed anger is from Shaytan and Shaytan is made from fire. Fire is extinguished with water. So whenever you are angry do wudhu.'

Think about what happened. If it is your fault then see the positive side and try to change yourself. If it is not your fault then have faith that the truth will always win and when the time comes you can explain. Imam Ali (pbuh) has said:

"Anger begins in madness and ends in regret."

Imam Ali Zaynul Aabideen (pbuh) had a slave who once dropped a bowl of hot soup on him whilst she was serving food. She saw that Imam was in a lot of pain. She thought that Imam would get angry and started to recite the above aya of Qur'an.

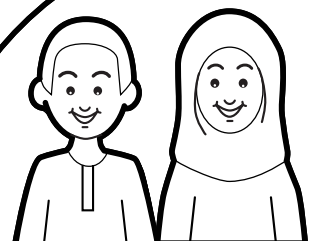

When she recited ..and those who swallow their anger...Imam told her he was not angry with her.

When she recited ..and those who forgive people...Imam said he had forgiven her. Finally, when she recited ..and Allah loves those who do good (to others), Imam set her free.

Imam not only swallowed his anger but also forgave the girl and set her free. As the followers of Imam the least we can do is to swallow our anger when a friend, relative or another Muslim says or does something which hurts us.

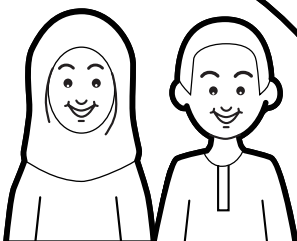

☺ BE CHEERFUL

The Prophet (pbuh) has said:

"You cannot please all the people with money but you can meet them with a cheerful face and good behaviour so that you may be liked by them. Wealth is limited but good akhlāq and cheerfulness never finishes."

A man from Shaam (Damascus) once came to Madina arriving in the presence of Imam Hasan (pbuh).

The man started abusing Imam Ali (pbuh).

Imam Hasan (pbuh) took him to one side and said:

"You must be very tired from your journey. Come with me and I shall give you food, drink and rest. We will talk later."

The man turned to Imam Hasan (pbuh) and said:

"I came to Madina as your worst enemy and now I am the best of your admirers through your akhlāq."

Imam Ali (pbuh) has said:

"A mu'min has a smile and cheerfulness on his/her face and sorrow in his/her heart."

Imam Ali (pbuh) was always cheerful in dealing with others so much so that some people considered it to be a weak point for a Khalifa, saying that a leader must be grim - a person others should be afraid of.

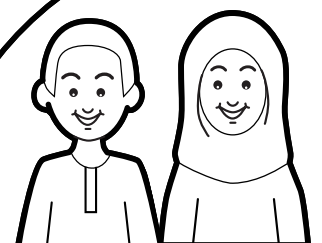

Allah says about the Prophet (pbuh) in the Qur'an:

"It was by the mercy of Allah that you are gentle with them, for if you would have been stern and fierce of heart they would have run away from you."

Qur'an -Suratu Aali-Imran 3:159

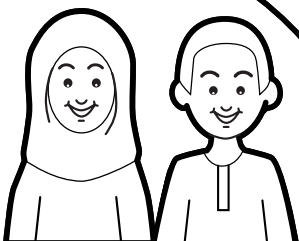

Be Cheerful

Write or draw the things that make you smile.

Also write or draw the things that do not make you smile!

Who do you smile for the most?

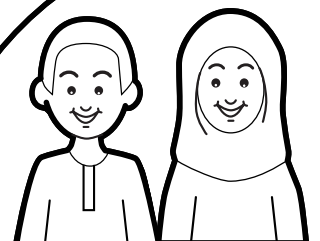
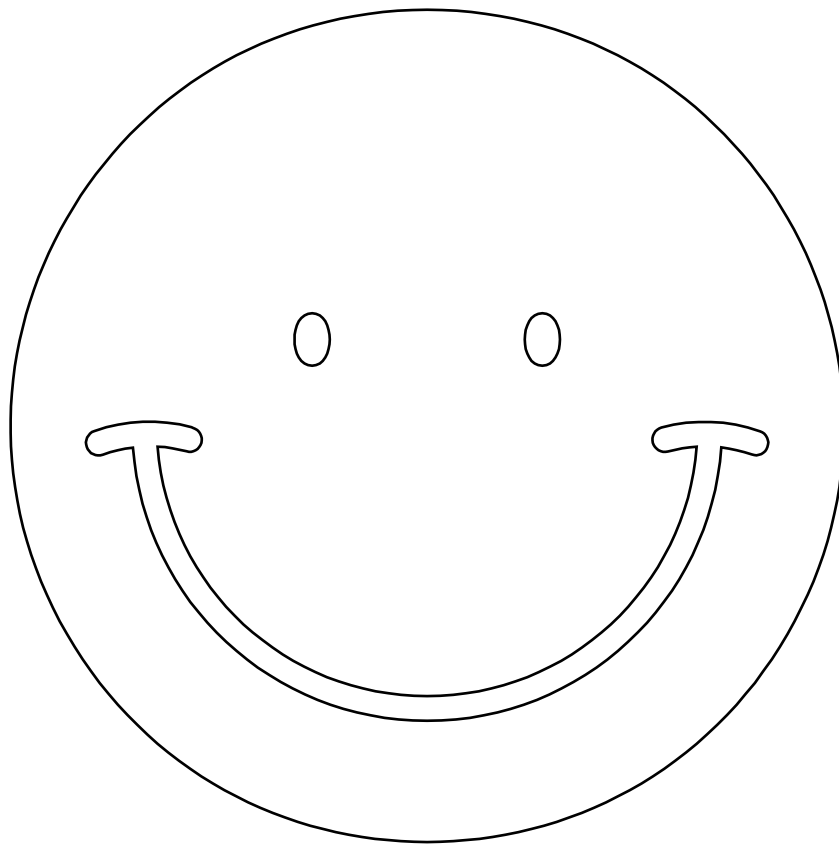

DO NOT ABUSE

"Indeed Allah is angry with one who uses abusive language towards others."

Imam Muhammad Al-Baqir (Pbuh)

A man once came to the gathering where Imam Ali Zaynul Aabideen (Pbuh) was present.

He held a grudge against Imam and started using abusive language insulting Imam in front of all the others. He then left abruptly.

After he left Imam told those who were present:

"You have seen how abusive this man was towards me. Now I wish to go to him with all of you and to give him a reply to what he has said!"

All those with Imam thought Imam would deal with him harshly. However, throughout the short walk to his house Imam was reciting the following aya of Qur'an:

"..And those who swallow their anger and forgive people; Indeed Allah loves the righteous ones."

Qur'an- Suratu Aali-Imran

3:134

When they reached the man's house they knocked on the door and called out to him.

He thought Imam and his companions had come to punish him. He came out fearing the worst only to find Imam smiling at him.

Imam said: "An hour ago you came to me and used abusive language. I have now come to tell you that if you have spoken the truth and the evil

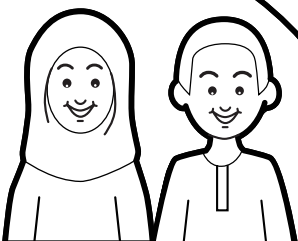

that you have said I have done exists then I pray to Allah that He may forgive me; However, if you have lied then I pray to Allah that He may overlook your sin and forgive you."

The man found himself helpless in front of such a generous attitude. He said:

"Yabna Rasulillah! None of the abusive things I said exist in you. In fact I am more deserving of possessing them. Please forgive me."

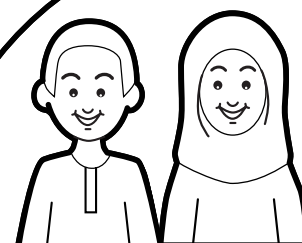

END OF A FRIENDSHIP

Two friends walked into a market together with the servant of one of them following behind.

As the two friends walked through the market the servant got left behind looking at the shops and talking to friends. When his master looked behind, he could not see him. After a while the servant appeared.

The master started telling off the servant saying bad things about his mother. Just as the bad words came out of his mouth, Imam Ja'fer As-Sadiq (Pbuh) who was the master's friend said:

"...You have abused his mother... I thought you were a Muslim with taqwa..." His friend said:

"O son of the Prophet! The servant is from Sind and so is his mother. She is not even a Muslim and it is all right if I said bad words about her."

Imam (Pbuh) said:

"I know that she was not a Muslim but every religion has its laws and rules. If a non-Muslim marries according to her religion then her children are legal children". And then Imam Ja'fer As-Sadiq (Pbuh) said:

"This is the end of our friendship".

They had entered the market as friends but left never to be seen together again.



DO NOT BELITTLE OTHERS

"Do not turn your face away from people scornfully.....Indeed Allah does not love any arrogant and boastful person."

Qur'an - Suratu Luqman 31:18

Anyone who wishes to be above others means that he/she wishes to humiliate and belittle others. The source of this always comes from an inferiority complex for otherwise no sensible person can imagine any difference between him/her and any other person. The only criteria in the eyes of Allah is Taqwa.

Imam Ja'fer As-Sadiq (Pbuh) has said:

The only reason a person suffers from the disease of arrogance is due to an inferiority complex which he/she sees in him/herself."

One who belittles others can identify his/her disease by the following symptoms:

1. He/she does not like to be equal to others in any matter.
2. He/she always wants to go ahead of others and sit at a higher place than others in a gathering.
3. He/she expects others to greet him/her first.
4. If anyone gives him/her advice he/she gets annoyed.
5. If he/she advises anyone it is with torment.
6. If his/her word is not accepted he/she gets angry.

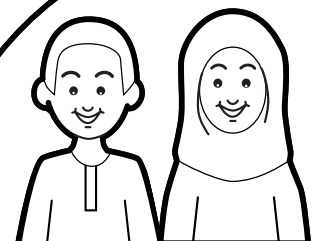

7. If he/she teaches he/she belittles the students reminding them of the favour done to them and considers them to be his/her servants.

One day the Prophet (Pbuh) was sitting in a circle with his companions when a poor man came in. His poverty was apparent by his tattered clothes. It is the akhlaq of a 'majlis' to sit where there is a vacant place and not look for a particular place to suit one's status, etc.

The poor man saw a space and sat down. It so happened that the space was near a rich man who gathered his clothes and pulled them towards himself as if to create a distance between him and the poor man. It seemed that the rich man was feeling a little uneasy.

The Prophet (Pbuh) was watching the behaviour of the rich man. He addressed him saying:

"Did you fear that some of his poverty might stick to you?"

The rich man replied:

"No! Ya Rasulallah! "

The Prophet (Pbuh) asked:

"Did you fear that something out of your wealth might be transferred to him?"

The rich man replied :

"No! Ya Rasulallah!"

The Prophet (Pbuh) asked a further question:

"Did you fear that your clothes might get dirtied by touching his clothes?"

The rich man replied:

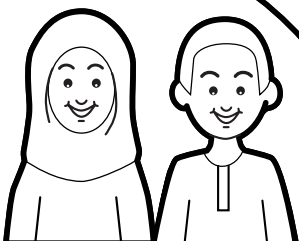

"No! Ya Rasulallah!"

"Then why did you move yourself away from him?" asked the Prophet (Pbuh)

The rich man replied:

"Ya Rasulallah! I admit I made a grave mistake. I would like to make amends and I would like to give half my wealth to this Muslim brother of mine."

When the poor man heard his words he said:

"Ya Rasulallah! I am not prepared to take his offer!"

The companions who were present there were surprised and said: "Why?"

The poor man replied:

"I fear lest with the wealth I am offered I too may become arrogant and one day may belittle one of my brothers in ISLAM in the manner in which he (the rich man) has treated me today."

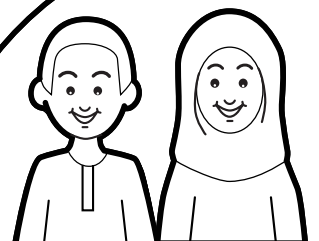

BIG AND SMALL SINS!

Two men came to Imam Ja'fer As-Sadiq (Pbuh) and said that they would like to do Tawba (ask for forgiveness and rectify) for their sins.

The first man said that he had done a lot of small sins whilst the second said that he had committed two big sins.

Imam told the first man to pick one small pebble for each small sin that he had committed.

He told the second man to bring a large boulder for each of his big sins.

After a while both men came back to Imam having brought what they were asked to bring.

Imam now asked both of them to put back every stone in its place.

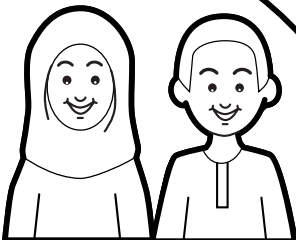
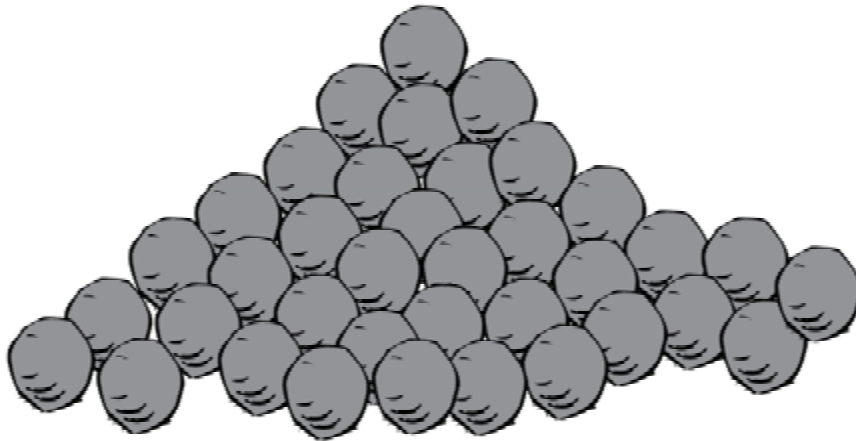

The man with the two large boulders found it difficult to carry them back in their original place but eventually he managed.

The man with the many small pebbles could not remember where he had picked all of them so he could not put them all back in their original place.

It is very difficult to do Tawba for the sins which seem small because we forget and take them for granted.

Imam Ali (Pbuh) has said:

“The biggest sin is that which the doer considers the smallest.”

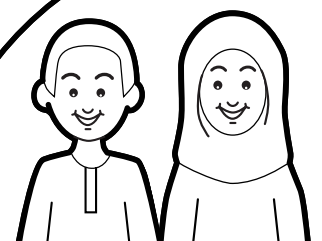
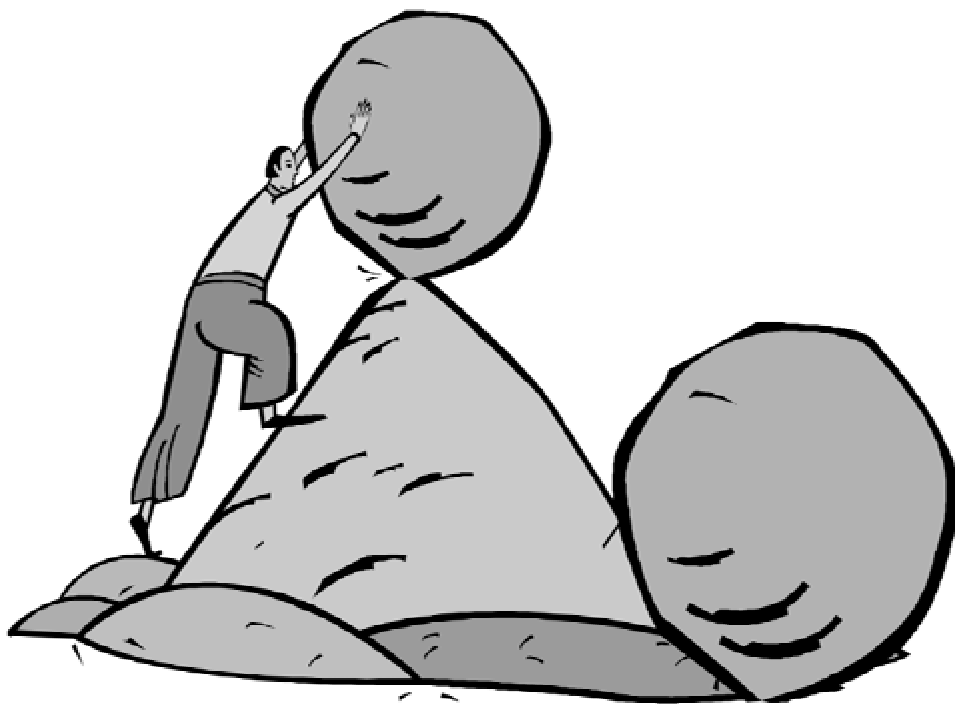

WATCHING TV

Watching too much Television causes tiredness and headaches but worst of all it takes one away from Allah. Even watching cartoons makes us start believing that maybe He-man is stronger than Allah or that Captain Planet controls the universe rather than Allah.

Television makes us lazy and angry as well. It becomes a bad habit which is very difficult to get rid of. We become like old stumps of trees waiting for rot to set in.

Television stops us from sitting together as a family, talking and discussing things. It is a conversation stopper and a baby-sitter which feeds our souls rot.

Discipline your watching of Television. At most watch half an hour a day of good programmes where you will learn something.

Before you switch the Television on ask yourself:

1. Am I going to learn from this programme?
2. Have I timed myself for half an hour?
3. Are there any haram things in the programme that I should not watch?
4. If Imam Mahdi (pbuh) were to visit me, would I be able to sit with him to watch this programme?

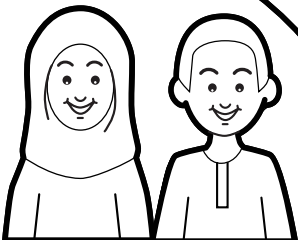

DUTIES TOWARDS PARENTS

Prophet Muhammad (pbuh) has said:

"Sitting with your parents for one hour is better than going for jihad. Even if only a word is spoken with a view to pleasing the parents, Allah is pleased."

Respecting parent's means:

1. Never raise your voice while talking to them.
2. Do not sit when they are standing.
3. Do not walk in front of them unless they tell you to do so.
4. Do not talk when they are talking.
5. Never correct them in front of others.
6. Do not make them angry or displeased with you.
7. Never argue or shout at them.

Always pray for them:

رَبِّ اَرْحَمُهُمَا كَمَا رَبَّيْنِي صَغِيرًا

"...Lord! Have mercy on them just as they had mercy on me when I was little..." Qur'an - Surat Bani Israil 17:24

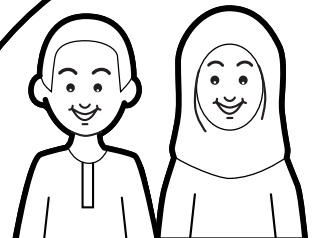

MANNERS FOR RECITING THE QUR'AN

I always do Wudhu before I start reciting the Qur'an.

I sit facing the qibla respectfully holding the Qur'an in my hands. If possible I place the Qur'an on a table or a Qur'an stand.

I cover my head as a sign of respect. (Cap for a boy and a scarf for a girl).

I always start the recitation with:

أَعُوذُ بِاللَّهِ مِنَ الشَّيْطَانِ الرَّجِيمِ
بِسْمِ اللَّهِ الرَّحْمَنِ الرَّحِيمِ

I read clearly and distinctly without rushing.

I never leave the Qur'an open or unattended.

As Imam Ali Zaynul Abedeen a.s. has taught us I always ask Allah:
"O Allah! Make the Qur'an a ladder by which I may climb to the place of safety."

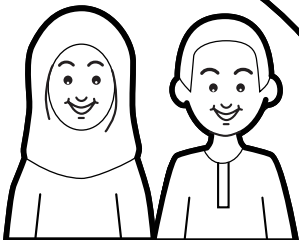
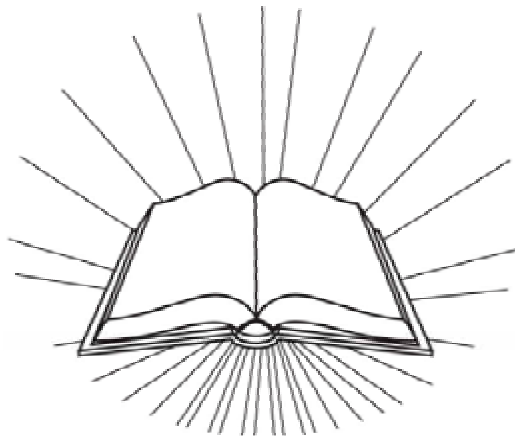

THE QUR'AN

The Qur'an was revealed to the Prophet (Pbuh) over a period of approximately 23 years.

The Qur'an is the direct word of Allah. Not only are the meanings holy but so are the words, so much so that even mere recitation is commendable and is considered an act of worship.

Looking at the word whilst reciting holds more thawaab.

It is **haram** to touch the words of the Qur'an without Wudhoo.

The first **ayaat** that were revealed were the first five of Suratul Alaq:

“Read in the name of Your Lord Who created,
He created man from a clot,
Read and Your Lord is the most Honourable,
Who taught by the pen,
Taught man what he knew not...”

The last **aya** revealed was the 3rd aya of Suratul Maidah (5):

“This day I have perfected your religion for you, completed My favour upon you, and chosen for you ISLAM as your religion.”

This was revealed at Ghadeere Khum on 18th Zulhijjah 10 a.h.

There are **114 suwer** in the Qur'an. The longest **sura** is Suratul Baqarah (2) with 286 **ayaat** covering one twelfth of the Qur'an; and the shortest being Suratul Kawthar (108) with 4 **ayaat**.

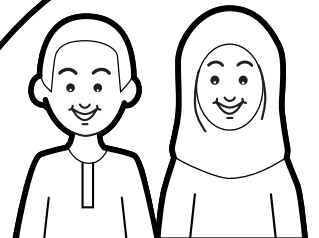

Suratul Inshirah (94) and Suratud Duhaa (93) are regarded as one **sura**; similarly Suratul Feel (105) and Suratul Quraish (106) are regarded as one. This is why they are not to be recited singly in salaa.

The Qur'an is divided into 30 equal parts (**Juz** – pl. **Ajza**) to enable the reader to finish the recitation in a month.

The Qur'an is also divided into 7 equal sections (**Manzil** – pl. **Manazil**) to enable one to complete in a week if so desired.

According to the AhlulBayt **Bismillahirrahmanirraheem** is the first **aya** of all the **suwer** and is a part of the **sura** except Suratut Tawba (9). It appears twice in Suratun Naml (27).

LET US USE CORRECT WORDS

Aya – One verse of the Qur'an. Aya means sign, every verse is a Sign of Allah.

Ayaat – Plural of Aya.

Juz – The Qur'an is divided into thirty equal parts. Each of these parts is a Juz (more commonly known as sipara).

Ajza – Plural of Juz.

Manzil – The Qur'an is also divided into seven parts. Each of these parts is a manzil.

Manazil – Plural of manzil.



Ruku – A group of ayaat marked with a ﴿ representing a section (paragraph) of the sura (more commonly known as makra)

Sajda – Prostration

Sajadaat – Plural of sajda.

Sura – One chapter of the 114 chapters of the Qur'an. Literally meaning enclosure.

Suwer – Plural of sura.

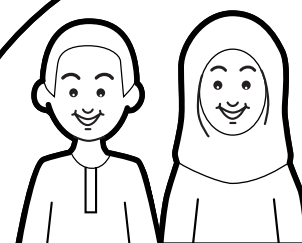

SURATUL KAWTHAR

The Prophet (Pbuh) had a son called Tahir who died in infancy. When he died some people (Umar & Hakam bin Aas) taunted him calling him 'Abtar' which means an animal without a tail - one who had no succession.

This surah was revealed in reply to those who taunted the Prophet (Pbuh)

بِسْمِ اللّٰهِ الرَّحْمٰنِ الرَّحِیْمِ

In the name of Allah, the Most Kind, the Most Merciful.

اِنَّا اَعْطٰیْنٰكَ الْكَوْثَرَ

Indeed We have given you Kawthar - the heavenly fountain of plenty. 'Kawthar' comes from the word 'kathara' which means plenty. The traditional description of Kawthar is that of a spring in Jannah to which we all can have access to provided we stick to those who have been granted it.

'Kawthar' also means abundance of descendants. It is a fact that none can correctly count the descendants of the Prophet (Pbuh) whereas those who taunted the Prophet (Pbuh) are unknown.

'Kawthar' also implies the abundance of good given to the Prophet (Pbuh) in this world and in the hereafter.

فَصَلِّ لِرَبِّكَ وَاَنْحِرْ

Therefore pray to your Lord and make a sacrifice.



Although the verses are addressed to the Prophet (Pbuh) it is directed to us to follow.

'Nahr' means sacrifice but means the raising of the hands to the (neck) when Takbeer is said - implying that God is greater than any/everything and we would sacrifice all for Him.

إِنَّ شَانِئَكَ هُوَ الْأَبْتَرُ

Certainly, your enemy shall be the one cut off.

This aya refers to those who taunted the Prophet (Pbuh) as 'Abtar'.

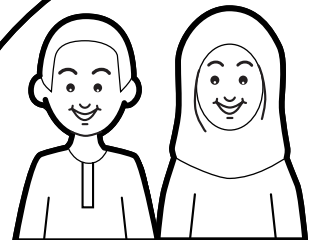

SURATUL 'ASR

The sura begins with Time and ends with sabr (Patience). Sabr is the shrinking of time. e.g. if we want to eat a fruit which is not yet ripe, we know we have to wait for it to ripen and we agree to do so. What we are doing is shrinking the time into "zero time".

بِسْمِ اللَّهِ الرَّحْمَنِ الرَّحِيمِ

In the name of Allah, the Most Kind, the Most Merciful.

وَ الْعَصْرِ

I swear by Time!

'Asr' literally means squeezing. It has been used for Time- in the sense of it's meaning the squeezing of the past unfolding as future.

It may refer to the era of the Prophet (Pbuh) or the time of Asr on Ashura; or as per a hadith of our 6th Imam -the era of Imam Al-Mahdi (Pbuh) Time is the most valuable commodity which man has...

If you look at the lives of great people - there is one thing in common that we all have with them and that is - 24 hrs in a day. The way they use their time has made the difference.

إِنَّ الْإِنْسَانَ لَفِي خُسْرٍ

Most certainly the human being is in a state of loss;

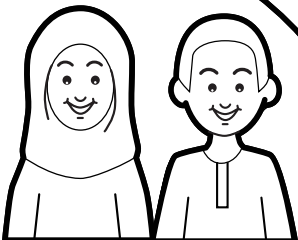

Man's lower nature is to be at a loss. Man's basic nature is to be confused, and dissatisfaction without any calm and peace - man fluctuates from one thought to the other, one idea to the other ... No sooner is one situation under control then he must move to another which is chaotic...

إِلَّا الَّذِينَ آمَنُوا وَعَمِلُوا الصَّالِحَاتِ وَتَوَّصَوْا بِالْحَقِّ
وَتَوَّصَوْا بِالصَّبْرِ

Except those who believe, and do good deeds, and advise each other to truth, and advise each other to patience. Advising each other to truth and to patience is 'Amr bil Ma'ruf ' and 'Nahyi anil Munkar '. The highest degree of patience is that which is exercised when one keeps away from 'haram'.

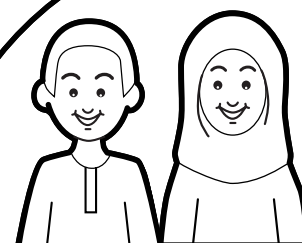

SURATUL LAHAB

بِسْمِ اللّٰهِ الرَّحْمٰنِ الرَّحِیْمِ

In the name of Allah, the Most Kind, the Most Merciful.

تَبَّتْ يَدَا اَبِيْ لَهَبٍ وَ تَبَّ

May the two hands of Abu Lahab perish, and may He perish.

Abu Lahab means father of flames.

His actual name was Abdul Uzza, and he was a man with a fiery character.

When the Prophet (Pbuh) called all his relations first to announce for the first time his prophet hood; he asked them all whether they would believe him if he told them that there was an army waiting behind the mountain. All replied that they would for they had never heard the Prophet (Pbuh) lie.

The Prophet (Pbuh) then announced that he had come from the one God as a messenger to preach the oneness of God.

Abu Lahab said "May you perish (die)! Is this why you have called us?"

He was once found walking behind the Prophet (Pbuh) throwing stones at him and shouting at the people not to listen to the Prophet (Pbuh)

He raised a large stone to throw at the Prophet (Pbuh) but his hands froze. The ayah refers to his raising of hands to throw the stone.

"Tabba" also means - to be lost or to lose - and it refers to the fact that whatever his hands did (whatever his actions were), he was to be at a loss.

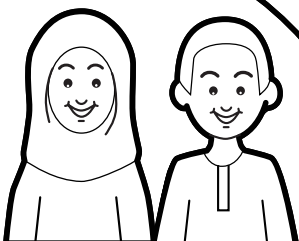

مَا أَغْنَىٰ عَنْهُ مَالُهُ وَ مَا كَسَبَ

His wealth and what he gains will be of no use.

When Abu Lahab was warned against the fire of Jahannam he said he would buy Jahannam with his wealth and escape it. This aya said that nothing will be of use to him.

سَيَصْلَىٰ نَارًا ذَاتَ لَهَبٍ

Soon shall he burn in the flaming fire.

When Abu Lahab will be in the fire; then only will he realise the return for his disbelief and the value of his wealth.

وَأَمْرَأَتُهُ حَمَّالَةَ الْحَطَبِ

فِي جِيدِهَا حَبْلٌ مِّن مَّسَدٍ

And his wife, the carrier of firewood,

Upon her neck is the halter (leash) of twisted rope.

Abu Lahab's wife was called 'Umme Jamila'. She was Abu Sufyan's sister. She also had a bad temperament like her husband.

Umme Jamila used to collect thorny sticks and bundle them up with a rope. In the night she used to spread them along the path that the Prophet (Pbuh) used to take to go to the mosque for prayers early in the morning.

The Prophet (Pbuh) used to move them aside but some of the thorns used to prick his feet and get entangled in his clothes.

She also used to incite people by carrying tales from one place to the other (gossip) and this also gave her the title as the 'carrier of firewood'.

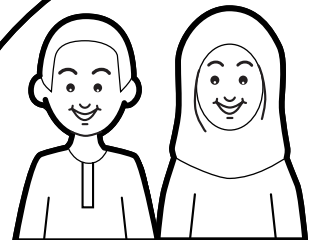

It showed her inner discontentment which showed in what she did outwardly; her inner thorns were carried on her back outwardly. The twisted rope around her neck implies that she was strangling her soul with the rope of her own making.

Note: Umme Jamila died strangled with the rope with which she carried the wood.

Abu Lahab died a week after the Battle of Badr and his body smelt so badly that no-one would bury him. In the end some slaves were hired to bury him.



SURATUL FEEL

This sura refers to the event that took place in the year of the birth of the Prophet (Pbuh). The people of the places around Makka were very jealous of the Quraysh and their position as guardians of the Ka'ba. One of these people was the Emperor of Abyssinia. He ruled over Yemen.

Through his representative in Yemen whose name was Abraha he built a large church in San'a (in Yemen) to compete with the Ka'ba. The church did not attract as many people as the Ka'ba in Makka as he had hoped for.

He therefore decided to destroy the Ka'ba under the leadership of Abraha. An army of elephants marched to Makka to attack and destroy the Ka'ba.

بِسْمِ اللّٰهِ الرَّحْمٰنِ الرَّحِیْمِ

In the name of Allah, the Most Kind, the Most Merciful.

اَلَمْ تَرَ كَيْفَ فَعَلَ رَبُّكَ بِاَصْحٰبِ الْفِیْلِ

Have you not seen how your Lord dealt with the companions of the elephant?

At that time the weapons that people had were either swords or spears. One who owned an elephant was regarded almost as an emperor. It was the best of 'weapons' one could possess.

Imam Khomeini (A.R.) recited this sura when the Americans sent their best helicopters (the most advanced of weapons) to Iran to rescue their spies and their helicopters were destroyed by 'sand'.

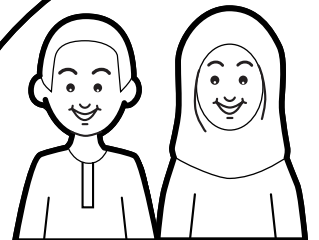

أَلَمْ يَجْعَلْ كَيْدَهُمْ فِي تَضَلُّيلٍ

Did He not cause their plans to end in confusion?

It refers to the confusion caused by the action of the tiny birds in the army of Abraha. Those who were hit by the pellets immediately fell dead, and the others created chaos amongst themselves.

وَأَرْسَلَ عَلَيْهِمْ طَيْرًا أَبَابِيلَ

تَرْمِيهِمْ بِحِجَارَةٍ مِّنْ سِجِّيلٍ

فَجَعَلَهُمْ كَعَصْفٍ مَّأْكُولٍ

And sent down flocks of birds upon them;
Pelting them with stones of baked clay;
So He made them as eaten straw.

'Abaabil' means flocks; and it does not necessarily refer to only birds but also to large overwhelming numbers.

God sent upon them a huge flock of birds with small stones in their beaks.

'Sijjeel' means stones like lumps of dry clay. There are many interpretations of this ayah. We do not know whether there was an actual storm of small creatures who pelted them with 'sijjeel' which penetrated their skins; or whether it was an illness brought by these birds which affected them so drastically.

We know that the mighty army was suddenly devastated, just as it was approaching the Ka'ba.

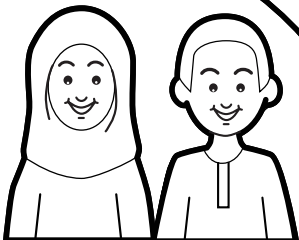

The result of the attack was that the enormous army became like straw eaten up. It is said that after this destruction the ground appeared as if a flat sheet made up of the thousands of men of the enemy army and their elephants had been laid down on it.

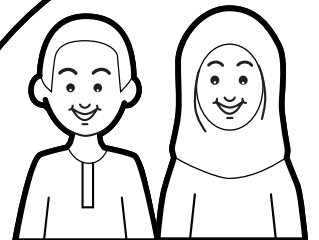

PROPHET DAWUD (pbuh)

Prophet Musa (pbuh) had saved the Bani Israil from Firaun and brought them to Palestine where they still had to fight with the Philistines who chased them out of their homes. In the last battle, the sacred box which had the original tablets of the Tawrat was lost. The Bani Israil felt quite lost.

They spent many years with no land or homes. Finally they approached Prophet Samuel (pbuh) and asked him to appoint a strong king for them so that they could get back their land.. On the command of Allah, Prophet Samuel (pbuh) appointed Taalut (Saul) as their king. The Bani Israil did not like the choice, saying that Taalut was a poor and unknown man. However, Prophet Samuel (pbuh) informed them that Taalut had been chosen because of his knowledge, wisdom and strength, and he would lead them to victory.

It took Taalut 20 years to find the sacred box which had the Taurat and once it was given back to the Bani Israil, they marched to Palestine. The leader of the Philistines was a huge man called Jaalut (Goliath). Just looking at Jaalut terrified the Bani Israil.

Prophet Dawud (pbuh) was present in the army of Taalut. He was very young and had not come to fight but to attend to his three older brothers who were soldiers, and to bring news of the war back to their father. When Taalut saw that Jaalut had terrified his army, he tried to encourage his men by promising them great rewards if they faced Jaalut. He even promised that he would marry his daughter to the man who killed Jaalut.

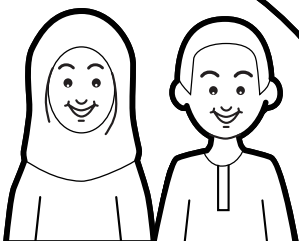

Prophet Dawud (pbuh) went to find out what was going on. He had never fought before he went to Taalut and said:

"I am fit to fight this devil because I have killed a tiger and a bear who attacked my father's sheep."

Taalut was impressed by his bravery and accepted his offer. He gave Prophet Dawud (pbuh) armour and told him to be careful.

Before Prophet Dawud (pbuh) approached Jaalut, he removed the heavy armour. He stood before the enemy, with a catapult and the staff with which he used to tend to his sheep. Before Jaalut could react to this challenge, Prophet Dawud (pbuh) had shot a stone from his catapult. The stone struck Jaalut's forehead with terrible force and brought him to the ground in a daze. Prophet Dawud (pbuh) then drew Jaalut's heavy sword and cut off his head. Having witnessed the death of their powerful leader, the Philistines were demoralised and ran away in panic.

Prophet Dawud (pbuh) married Taalut's daughter Mikâl. He was also made commander-in-chief of Taalut's army.

After Taalut died Prophet Dawud (pbuh) became the king.

Allah blessed him with a beautiful voice and revealed the Zabur (Psalms of David). When he used to recite from it, the mountains and the birds would also join through him.

Iron was as soft as wax in his hands, and he used to make special, light-weight battle armour made of iron ringlets joined together. By selling these to the army, he earned his livelihood.

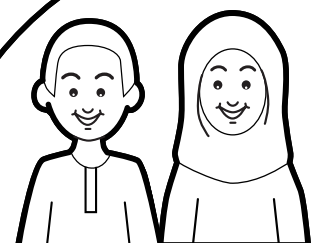

Indeed We granted Dawud a blessing, saying, "O Mountains! sing the praise of Allah along with him, and you too, O Birds!." And We made iron soft for him."

Qur'an -Suratus Saba 34:10

Prophet Dawud (pbuh) ruled for many years. After him his youngest son Prophet Sulayman (pbuh) became king.

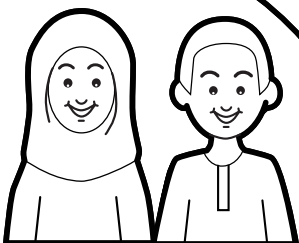

PROPHET DAWUD (pbuh)

Nineteen sons

Prophet Dawud (pbuh) had nineteen sons. Allah had granted Prophet Dawud (pbuh) the Zabur. He also became King of his people.

Each of his sons hoped to inherit their father's throne. Allah revealed to Prophet Dawud (pbuh) some questions to put to each of his sons. Whoever answered the questions correctly, would inherit his father's throne.

One day, Prophet Dawud (pbuh) called all his sons in the presence of all the scholars and leaders of all the tribes in his kingdom. He asked them all the following questions:

- 1) Which is the nearest thing to a human being?
- 2) Which is the furthest thing to a human being?
- 3) Which two things are attached to each other?
- 4) Which is the most shocking thing?
- 5) Which two things remain unchanged?
- 6) Which two things are always different?
- 7) Which two things are opposed to each other?
- 8) What is the action the result of which is good?
- 9) What is the action the result of which is bad?

Only the youngest son, Prophet Sulayman (pbuh) stood up and gave the following answers

- 1) The nearest thing to a human being is the hereafter (death may come at any moment)
- 2) The furthest thing from a human being is the time which has passed away.

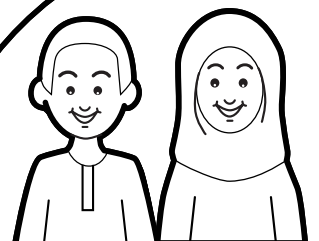

- 3) The two things that are attached to each other are the body and the soul.
- 4) The most shocking thing is a dead body (a body without a soul).
- 5) The two things which remain the same are the sky and the earth.
- 6) The two things which are different are the night and day.
- 7) The two things opposed to each other are life and death.
- 8) The action, the result of which is good is patience at the time of anger.
- 9) The action, the result of which is bad is haste at the time of anger.

Prophet Sulayman (pbuh) was appointed the successor to his father's throne.

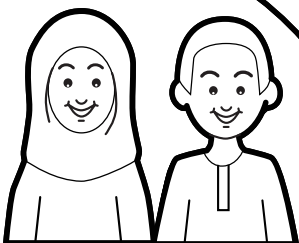

PROPHET SULAYMAN (pbuh)

The valley of ants

وَحِشْرَ لُسُلَيْمَانَ جُنُودَهُ مِنَ الْجِنِّ وَالْإِنْسِ وَالطَّيْرِ فَهُمْ يُوزَعُونَ
حَتَّىٰ إِذَا أَتَوْا عَلَىٰ وَادِ النَّمْلِ لَقَا نَمْلَةً يَأْتِيهَا النَّمْلُ أُدْخِلُوا
مَسَاكِنَكُمْ جَ لَا يَحِطُّنَكُمْ سَلِيمًا وَجُنُودَهُ لَا وَهُمْ لَا يَشْعُرُونَ

"Sulayman's army consisting of men, jinn and birds were gathered together in his presence in ranks. When they arrived in the valley of ants, one ant said to the others - Enter your houses lest Sulayman and his army crush you whilst they do not know"

Qur'an Suratun Naml - 27:17,18

Prophet Sulayman (pbuh) had a large army of men, jinn and animals.

He was once marching with his army to a place called the valley of ants which had a lot of gems and valuable metals buried in it.

In the valley there were large ants which stopped people from coming into the valley.

When the chief of the ants saw the army of Prophet Sulayman (pbuh) coming he told all the other ants to go into their holes (houses) in case Prophet Sulayman (pbuh) and his army would crush them.

Prophet Sulayman (pbuh) could understand the language of the animals and the insects and he heard what the chief of the ants said.

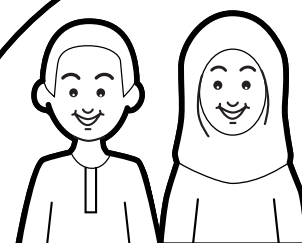

Prophet Sulayman (pbuh) smiled and asked his army to be careful not to hurt the ants. He thanked Allah for having given him the wisdom to be able to save the lives of the ants.

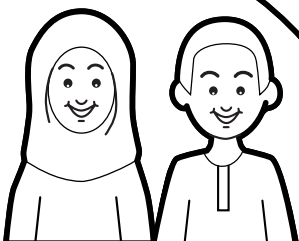
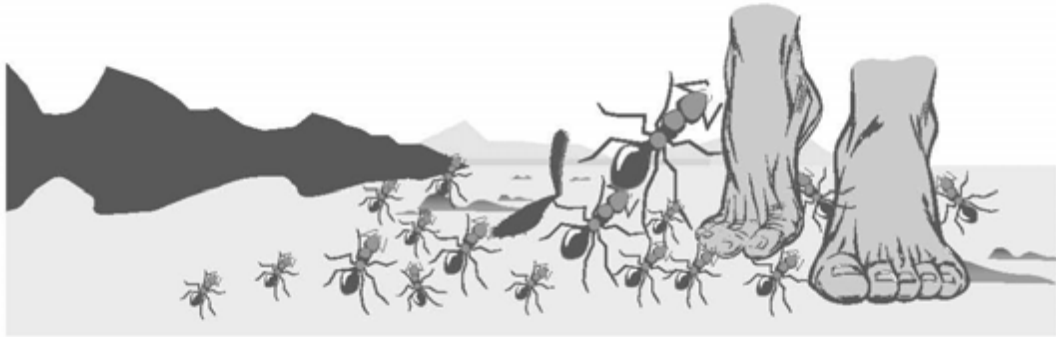

PROPHET SULAYMAN (Pbuh)

He was thirteen years old when his father Prophet Dawud (Pbuh) died. Allah granted him with the greatest kingdom that any king has ever ruled over. He was also granted the blessing of knowing the language of the birds and the animals. Even the wind would obey him. His army consisted of men, jinn, animals and birds.

He was once marching with his army to a place called the Valley of ants which had a lot of gems and valuable metals buried in it.

In the valley there were large ants which stopped people from coming into the valley.

When the chief of the ants saw the army of Prophet Sulayman (Pbuh) coming, he told all the other ants to go into their holes (houses) in case Prophet Sulayman (Pbuh) and his army crush them.

Prophet Sulayman (Pbuh) heard what the chief of the ants had said.

Prophet Sulayman (Pbuh) smiled and asked his army to be careful not to hurt the ants. Prophet Sulayman (Pbuh) thanked Allah for giving him the wisdom to understand and to be able to save lives of the ants.

One day Prophet Sulayman (Pbuh) noticed that his messenger bird - Hud Hud was missing.

A little while later the Hud Hud came back and reported to him saying: "...I have brought to you information from Saba (Sheba). Indeed I found a woman ruling over them and she has been given plenty and a great throne. I found her and her people worshipping the sun instead of Allah....."

Qur'an Suratun Naml-27:23,24

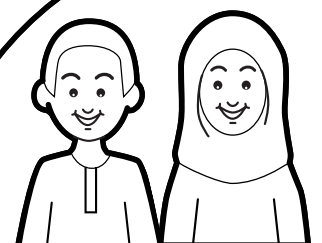

Prophet Sulayman (Pbuh) sent a letter to Bilqees, the Queen of Saba, saying: "In the name of Allah, the Kind, the Merciful. Do not elevate yourself and come towards me in submission to Allah (as a Muslim)."

Qur'an Suratun Naml 27:30,31

When Bilqees received the letter, she consulted her ministers and decided to send Prophet Sulayman (Pbuh) gifts and then wait for his reaction.

Prophet Sulayman (Pbuh) welcomed the messengers and asked for the reply to his letter. When they presented him with the gifts, he said:

"What are these riches? I have been given such blessings from Allah that are matched by none. Return to your country and inform your Queen that I am sending such an army towards Saba that no one will be able to defeat."

When Bilqees received this message and the report about the power of Prophet Sulayman (Pbuh), she decided to submit herself before him and accept his invitation to embrace Islam.

When Prophet Sulayman (Pbuh) learnt that she was coming to his kingdom, he turned to his people and said:

"Which of you can bring me her throne before they come here in submission?"

Qur'an Suratun Naml 27:38

One jinn said:

"I will bring it before you rise from your place...."

Qur'an Suratun Naml- 27:39

But one who had been taught the special name of Allah by Prophet Sulayman (Pbuh) said:

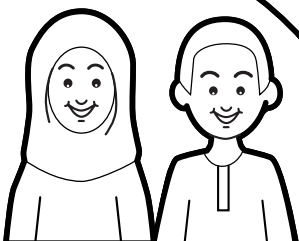

Said he who had some knowledge of the Book, "I will bring it to you

before your eye blinks", and when he (Sulayman) saw the throne settle beside him, he said, "This is by the Grace of my Lord so that He may test whether I am grateful or ungrateful..."

Qur'an Suratun Naml - 27:40

In preparation for the arrival of Bilqees, Prophet Sulayman (Pbuh) had ordered a palace of glass to be built. Under the glass floors, there was water with various kinds of fish swimming in it. When Bilqees arrived, he took her to the palace.

Bilqees was fooled by the appearance of water and hitched up her dress showing her bare feet to stop it getting wet. When she realised her mistake, she at once understood what Prophet Sulayman (Pbuh) was trying to tell her. He was showing her that things are not always what they seem, and even if the sun she worshipped was the most powerful thing to see, it was Allah who created it.

One day Prophet Sulayman (Pbuh) called all his army of men, jinn, animals and birds together. He wanted to inspect them all. He climbed on top of his palace to see them. It was there whilst he was viewing his kingdom that the angel of death came. Prophet Sulayman (Pbuh) was still leaning on his staff (stick). It was only when a worm ate through the stick and he fell that the men and jinn in his army realised that he had died.

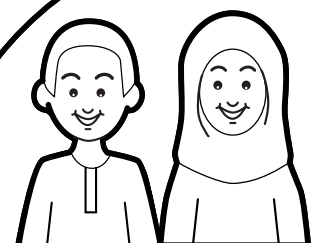

PROPHET SULAYMAN (Pbuh)

“O Sulayman! At this moment of time, I am better than you”

As Prophet Sulayman (Pbuh) was walking through the valley of the ants, the chief of the ants warned his fellow ants of the coming of the army, advising them to go into their homes to avoid being crushed.

When Prophet Sulayman (Pbuh) heard the warning of the chief of ants, he smiled and walked up to him, gently lifting him on the palm of his hand.

"Don't you know that I am the Prophet of Allah and that I would not harm any of Allah's creatures?" Sulayman asked the chief ant.

"Of course I do!" Said the chief "But, I feared that if my fellow ants would see the grandeur of your army, they would underestimate the grace of Allah which they receive and may become ungrateful."

The chief ant then asked Prophet Sulayman (Pbuh) "May I ask you a question?"

"Yes!" said Prophet Sulayman (Pbuh)

"Who is better at this moment in time?" asked the chief ant

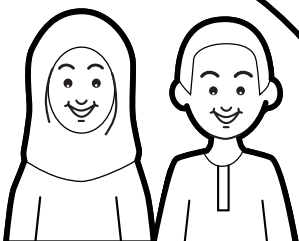

"Why don't you answer the question yourself!" Prophet Sulayman (Pbuh) said.

The chief ant replied:" At this moment in time, I am better than you for I am standing on the palm of a Prophet of Allah, whilst you O Prophet! are standing on the ground!"

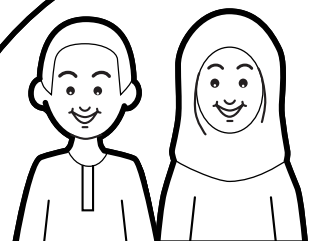

PROPHET YUNUS (pbuh)

The Big Fish

The people of Ninevah just would not listen. Allah had sent Prophet Yunus (pbuh) to them to tell them to believe in Him and to be good Muslims. Prophet Yunus (pbuh) tried very hard but the people would laugh at him and just not listen.

Prophet Yunus (pbuh) got so fed up that he decided to leave the town of Ninevah. He went to the seashore and when he saw a boat leaving he boarded it and sailed away. Soon the sea became rough and the waves rose high as a storm hit them. The wind was blowing hard and the boat was being tossed from side to side.

The people on the boat decided to throw one man out to make the boat lighter. They drew lots and the name of Prophet Yunus (pbuh) came. He was thrown into the sea.

Allah sent a big fish which swallowed Prophet Yunus (pbuh) He found himself in the darkness of the tummy of the big fish. Prophet Yunus (pbuh) realised his mistake of leaving the people of Ninevah.

He prayed to Allah asking for forgiveness. He said:

....لَا إِلَهَ إِلَّا أَنْتَ سُبْحَانَكَ إِنِّي كُنْتُ مِنَ الظَّالِمِينَ

.... There is no god except You; Glory be to You; Indeed I have done wrong.

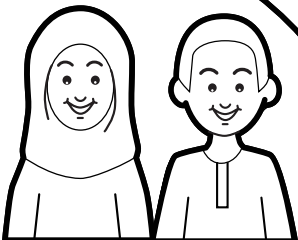

Qur'an - Suratul Ambiya 21:87

Allah accepted his dua and told the big fish to drop Prophet Yunus (pbuh) on the seashore.

Prophet Yunus (pbuh) was feeling very sick. Allah made special plants to grow around him and give him shade until he was better.

When he was better he went back to the people of Ninevah and started telling them about Allah. Finally, they believed in Allah.

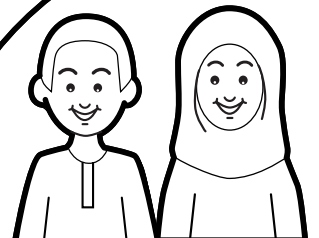

Prophet Yunus (pbuh)

Label and colour in the seven parts which must touch the ground during Sijda:

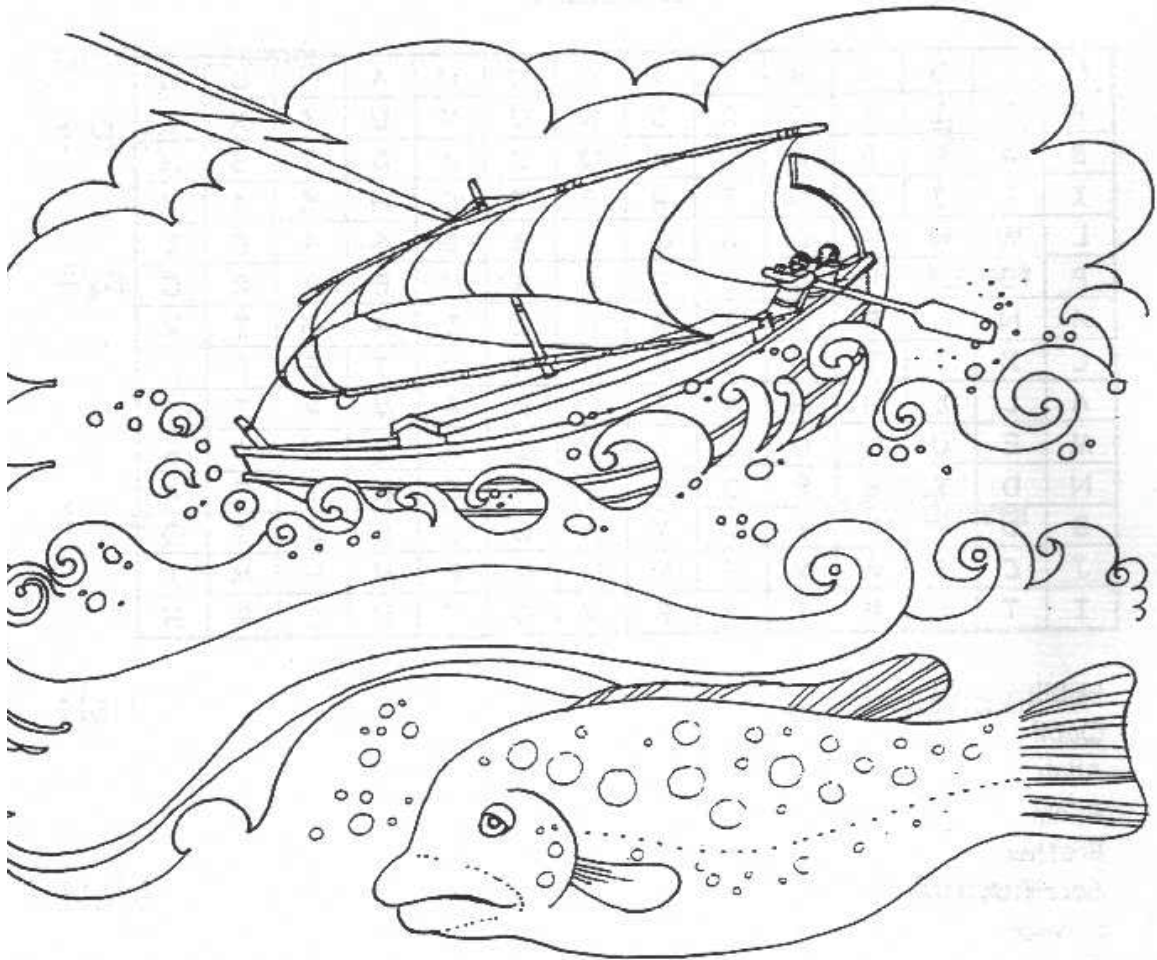

Fish
 Ninevah
 Obey
 Plant
 Prayed

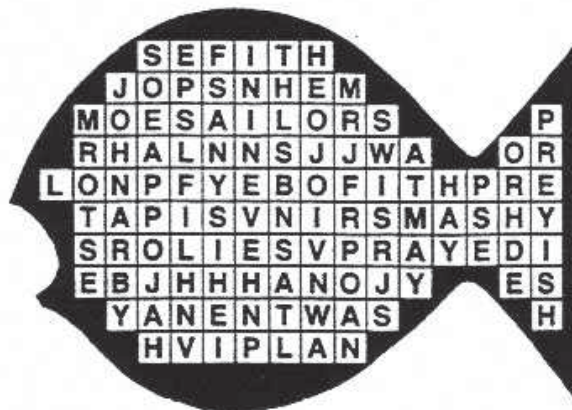

Sea
 Sorry
 Sailors
 Storm

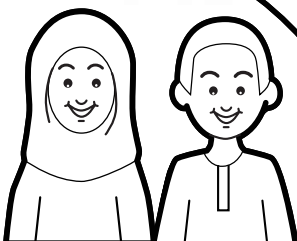

PROPHET IBRAHEEM (pbuh)

Say: Bismillahir rahmaanir raheem

بِسْمِ اللَّهِ الرَّحْمَنِ الرَّحِيمِ

Prophet Ibraheem (pbuh) loved having guests.

He would walk near the main road near his house every day and when he saw any traveller, he would invite them home for food and rest. On days, when there were no travellers, he would be unhappy.

Once, for three days no traveller passed by. Prophet Ibraheem (pbuh) was very sad. He too did not eat. Each morning he would go to the main road, hoping that someone would pass by.

After three days, he saw an old man on a camel. Prophet Ibraheem (pbuh) invited the man home. To his delight, the man accepted the invitation.

When they sat to eat, Prophet Ibraheem (pbuh) recited

بِسْمِ اللَّهِ الرَّحْمَنِ الرَّحِيمِ

He noticed that the old man did not say anything. Prophet Ibraheem (pbuh) asked him why he did not remember Allah before eating. Was not Allah his Creator and the Provider of the food?

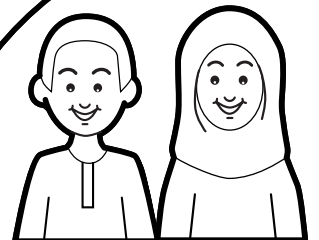

The old man replied that it was not a custom of his religion as he was one who worshipped fire. Prophet Ibraheem (pbuh) was annoyed and asked the man to leave his house.

As soon as he had sent the man away, the angel Jibrail came with a message from Allah. Jibrail told Prophet Ibraheem (pbuh) that Allah had been looking after that man despite him worshipping fire for seventy years. Could Prophet Ibraheem (A.S) not tolerate him for one meal?

Feeling ashamed, Prophet Ibraheem (pbuh) ran after the old man. He apologised for his behaviour and returned home with him to complete their meal.

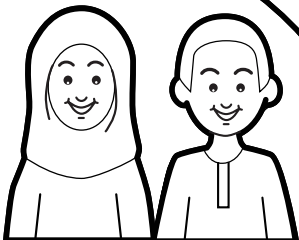

PROPHET IBRAHEEM (pbuh) Khalilullah

Prophet Ibraheem (pbuh) was given the title 'Khalilullah' which meant the friend of Allah.

When the angel of death came to Prophet Ibraheem (pbuh) and said that it was time for him to return to Allah; Prophet Ibraheem (pbuh) told him that he was a friend of Allah so why would a friend kill a friend.

Israil, the angel of death took his message to Allah.

The answer came:

"O Ibraheem ! Does a friend refuse an invitation from a friend to come to Him?"

*“Indeed we
are from Allah and
indeed to Him we
will return.”*
(2:156)

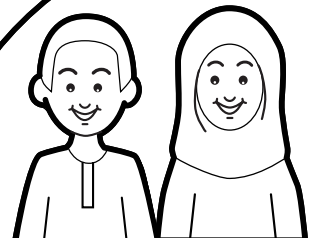

PROPHET MUHAMMAD (pbuh)

Prophet Muhammad (pbuh) was looked after by his grandfather Abdul Muttalib and his uncle Abu Talib because his father had died before he was born.

When he grew up he got married to Sayyida Khadija (pbuh) she was a very good lady who gave all her money for Islam. They had a daughter called Sayyida Fatima Zahra (pbuh)

The people of Makka used to believe in many gods which they made out of wood, flour, stones and other things. They kept them in the Ka'ba. Prophet Muhammad (pbuh) told the people of Makka that there is no God except Allah and that he Muhammad was the messenger of Allah. Allah sent him messages through the angel Jibrail. One message is called an aya. The messages are the ayaat of the Qur'an.

The Makkans did not like Prophet Muhammad (pbuh) and wanted to kill him so he left Makka and went to Madina. This journey of his is called Hijra from which date the Muslim calendar begins. Most of the people of Madina became good Muslims.

As ordered to him by Allah the Prophet (pbuh) chose Imam Ali (pbuh) to be the leader after him at a place called Ghadeer. At Ghadeer the Prophet (pbuh) also told the Muslims that he would soon be returning to Allah and that after him they should follow the Qur'an and his Ahlulbayt.

He died on the 28th of Safar in Madina when he was 63 years old.



PROPHET MUHAMMAD (pbuh) THE SUN OF KNOWLEDGE TO OUR PATH

Colour the sun below and for every ray that you see write down the different things that Rasulullah has taught us. One has been done for you.

Honesty

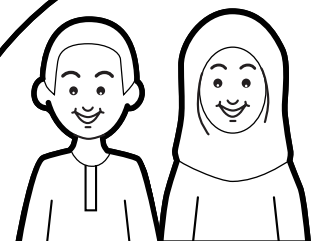
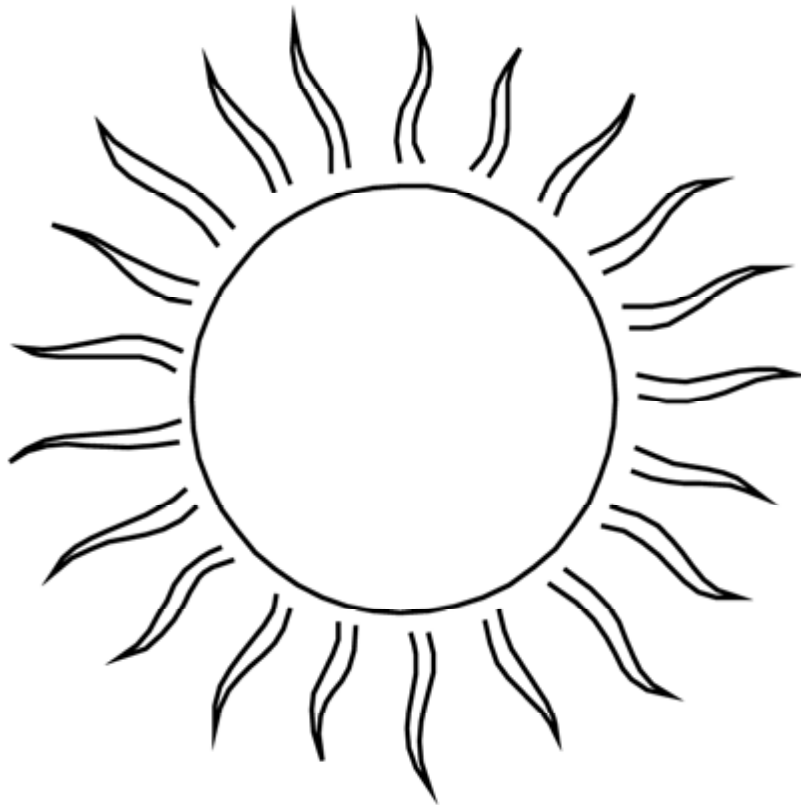

Prophet Muhammad (pbuh)

Put the following sentences in order in the flow chart.

- The people follow the Prophet's teachings.
- The people forget the Prophet's teachings.
- Allah sends a Prophet to guide the people.
- The people do evil deeds and commit shirk.

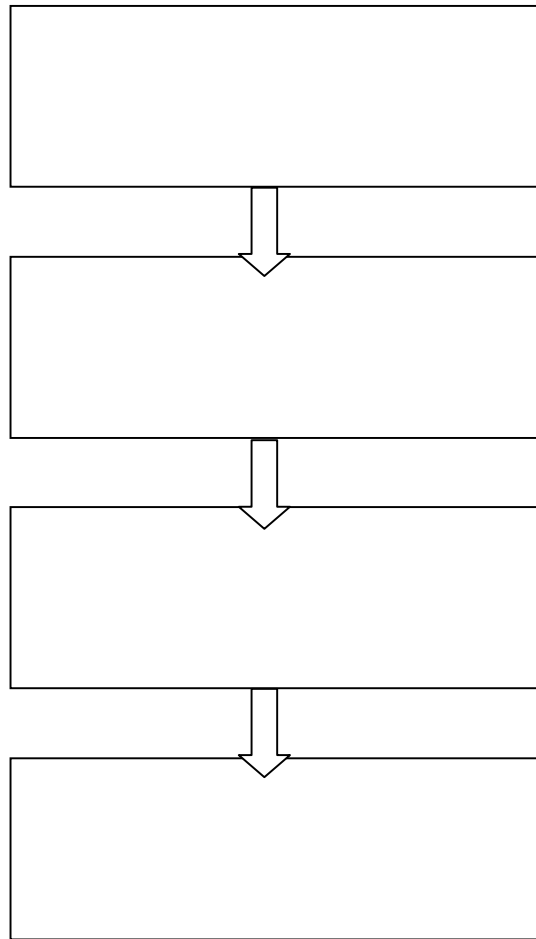

What did the Makkans do before Islam? How had they forgotten the teachings of Prophet Ibrahim (pbuh)?

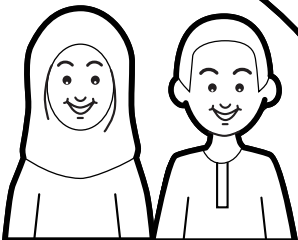

Prophet Muhammad (pbuh)

Numbers

1. What year was the Prophet (pbuh) born in?
2. How old was the Prophet (pbuh) when he received the first revelation?
3. What number Surah is Suratu Muhammad?
4. How many years did the Prophet (pbuh) preach Islam in Makka?

Qur'an

1. What were the first ayaat to be revealed to the Prophet (pbuh)?
2. What was the last aya to be revealed?
3. Where in the Qur'an does Allah console the Prophet (pbuh) on the wafat of his young son?
4. What is the difference between the revelation of the Qur'an on laylatul Qadr as a whole and it's revelation over 23 years?

Life

1. What are the three methods with which the Prophet (pbuh) established Islam?
2. The life of the Prophet (pbuh) can be divided into 3 parts – name them!
3. What was the main aim of the Prophet (pbuh) – use the Qur'an to justify your answer

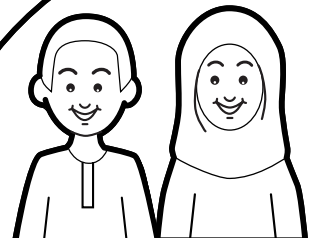

4. The Prophet (pbuh) was labelled with three names by the media machine of the Quraysh – all three are found in the Qur'an – What were these?

Finally quote one hadith of the Prophet (pbuh)

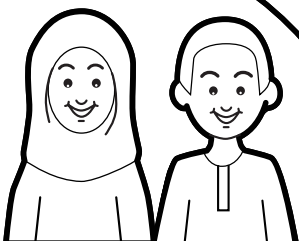

The Holy Prophet (pbuh)

Read the following questions and circle the correct answers

1. The Prophet was born in _____

- a. Makka b. Madina c. Iran d. Karbala

2. His father's name was Hazrat _____

- a. Ali b. Jaffer c. Hamza d. Abdullah

3. His mother was Sayyeda _____

- a. Hajra b. Fatima c. Amina d. Khadija

4. His enemies called him _____ & _____

- a. Truthful & Trustworthy b. Humble & Polite
c. Kind & Merciful d. Brave & Courageous

5. He received his first revelation when he was in the _____

- a. Cave of Mt. Arafat b. Cave of Mt. Hira
c. Cave of Jabal Al-Nur d. Cave of Mt. Sinai

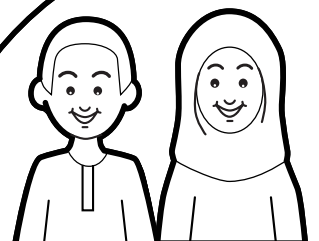

6. The first migration was made to _____

- a. Madina b. Makka c. Abyssinia d. Egypt

7. The Ansaar are the people who _____

- a. People of Madina who helped the Prophet after his migration.
b. People of Najran with whom Mubahila was to take place
c. People of Makka with whom the Prophet signed a treaty
d. Plotted and wanted to kill the Prophet.

8. The first battle at the time of the Prophet was battle of

- a. Siffeen b. Uhad c. Khandaq d. Badr

9. What is Fadaq?

- a. A piece of land given to Sayyida Zahra as a gift.
b. 2nd battle of Islam
c. A Jewish fort.

10. _____ was an enemy who troubled the Prophet

- a. Yazid b. Muawya c. Abu Sufyan d. Marwan

11. _____ is a famous companion of the Prophet

- a. Ahmed b. Qambar c. Hilal d. Salman

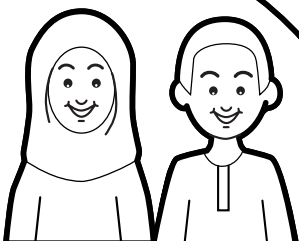

12. The Prophet is buried in _____

a. Jannat ul Baqee
c. Ka'ba

b. Masjidun Nabi
d. Shaam

13. The Qura'n was revealed over _____ years

a. 23

b. 40

c. 63

d. 10

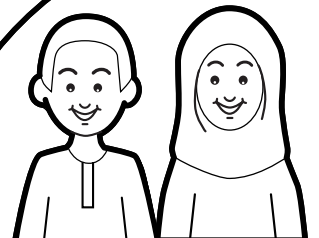

PROPHET MUHAMMAD (pbuh)

AMR - HASHIM

He who broke bread!

His real name was Amr. His people in Arabia were having difficult times. No rain had fallen for months and therefore nothing grew from the hard baked earth.

Amr took all that he had and went to another country to swap it for food.

He got flour and when he came back home to Makka he made bread for his people.

He killed all the camels he had to make meat gravy for the people to soak their bread in.

The people were so grateful. They called him HASHIM, which means one who breaks bread.

Hashim is the great grandfather of our Prophet Muhammad (pbuh)

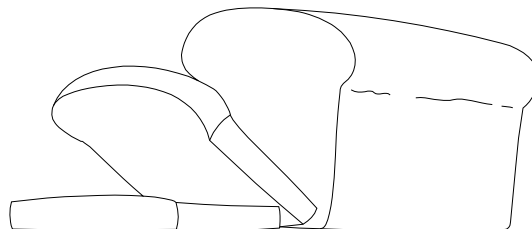

PROPHET MUHAMMAD (pbuh) ABDUL MUTTALIB SHAYBATUL HAMD The well behaved boy with white hair

He was born to Salma in Yathrib, the city which was later to be called Madina. His father Hashim had died in Makka and did not see his son.

When he was born he had a patch of white hair on the front of his head and so his mother called him Shayba, which means one with white hair.

He grew up to be a very well behaved young boy with excellent akhlaq. The people of Madina were so impressed with his akhlaq that they called him Shaybatul Hamd, which means the one with white hair who is praiseworthy.

A man from Makka once visited Madina and saw Shaybatul Hamd. When he returned to Makka he told Hashim's brother Muttalib that he had seen his brother's son.

Muttalib went to Madina and with Salma's permission he brought the young Shaybatul Hamd to Makka.

When the people of Makka saw Muttalib with the young boy entering the town they thought he was Muttalib's slave. In Arabic slave is 'abd' and so they called him **Abdul Muttalib** which means slave of Muttalib.

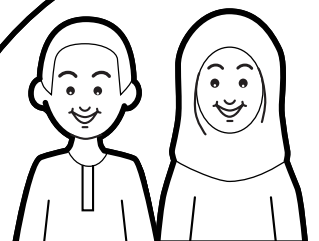

Muttalib tried to explain that this was his nephew but the name stuck.

Abdul Muttalib grew up to be the chief of Makka. He had lots of sons of whom one was Abdullah (pbuh) who was the father of Prophet Muhammad (pbuh).

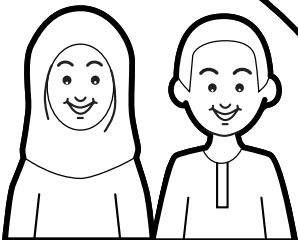

AAMUL FEEL

THE YEAR OF THE ELEPHANT

The king of Yemen built a beautiful church. There were beautiful silk carpets hanging on the walls and it was decorated with the best of everything. He wanted people to come to pray in Yemen rather than go to visit the Ka'ba in Makka.

In spite of all his efforts people still went to Makka.

He decided that the only solution was to destroy the Ka'ba. He chose one of his strongest and bravest man called Abraha to take an army of elephants to destroy the Ka'ba.

On the way to Makka, the army of Abraha destroyed everything in their way and stole hundreds of camels. Amongst them were some camels that belonged to Abdul Muttalib who was Prophet Muhammad's (pbuh) grandfather.

Abdul Muttalib knew that Abraha was coming to destroy the Ka'ba. He ran to the Ka'ba and prayed to Allah.

"O Allah! Save Your house and do not let them destroy it!"

Then he went to Abraha.

"Why do you wish to see me?" said Abraha.

Abdul Muttalib said he wanted his camels returned.

Abraha was shocked!!

"I have come to destroy the Ka'ba. You are the chief of Makka and the guardian of the Ka'ba and all you are worried about is your camels!"

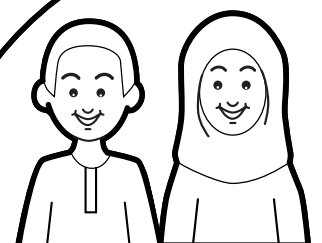

Abdul Muttalib replied:

"The camels belong to me, and so I ask for their return. The Ka'ba belongs to Allah and He will look after it Himself".

When Abraha heard this he returned the camels and marched forward to destroy the Ka'ba. Allah sent a flock of birds that flew over the army pelting them with small stones of baked clay which killed the elephants and the soldiers.

All except Abraha were destroyed and he rushed back to Yemen to tell the King what had happened. He was followed by one of the birds.

"What sort of amazing birds were these!" asked the furious king.

Abraha looked up and showed him. The bird threw a stone and Abraha died on the spot in front of the King.

It was in this year that our Prophet, Muhammad (pbuh) was born on the 17th of Rabi ul Awwal.

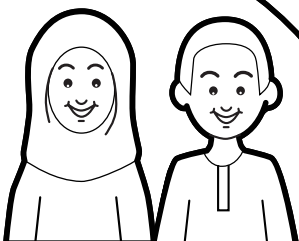

HAZRAT ABDULLAH (Pbuh) & SAYYIDA AMINA (Pbuh)

The Christian priests had a shirt that belonged to Prophet Yahya (Pbuh) They knew from their scriptures that when the father of the last Prophet would be born, blood would appear on the shirt.

They knew therefore when Hazrat Abdullah (Pbuh) was born and were searching for him.

He was his father's favourite son.

Abdul Muttalib had vowed that when he had ten sons he would sacrifice one. He drew lots and the name of Abdullah came up. Abdullah was very good and much liked by the people of Makka. When they saw that Abdul Muttalib was going to sacrifice him they persuaded him to go to a wise woman in Yathrib who could tell him of an alternative sacrifice.

It was agreed that lots would be drawn using camels. 10 lots were drawn of 10 camels each. Eventually 100 camels were sacrificed and Abdullah was saved.

The Prophet (Pbuh) used to say that he was the son of two sacrifices - Ismail & Abdullah.

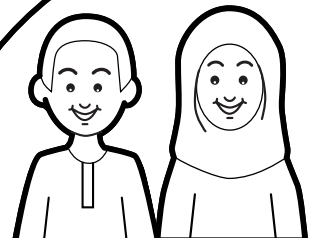

Abdul Muttalib dreamt that Abdullah should be married to Amina daughter of Wahab. They were married a year before the 'Year of the Elephant'.

When Sayyida Amina (Pbuh) was pregnant, Abdullah went with a trade caravan to Syria. On the way back he fell ill and died before the Prophet (Pbuh) was born. He is buried in Madina.

He left some camels, goats and a slave girl called Umme Ayman which were given to the Prophet (Pbuh)

Sayyida Amina was very sad after her husband died. When the Prophet (Pbuh) was six years old she too died on the way back from visiting Abdullah's grave. She is buried in Abwa, a place between Makka and Madina.

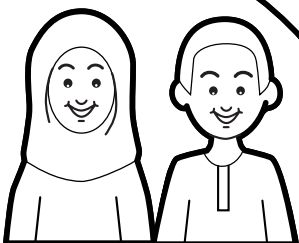

BIRTH OF PROPHET MUHAMMAD (Pbuh)

Imam Ja'fer As-Sadiq (Pbuh) has said that Allah created the light of Prophet Muhammad (Pbuh) before any of his creations.

He was born in the year of the Elephant (570 C.E.) in the month of Rabi ul Awwal. It was just after sunrise on Friday the seventeenth.

Shaytan who had been previously allowed to visit the heavens suddenly found that he could not go.

He went to the Ka'ba disguised as a little bird and saw angels celebrating. Jibrail saw him and recognised him. He was asked to leave but asked Jibrail to tell him what had happened. Jibrail told him that the last of the Prophets; Muhammad (Pbuh) was born. Shaytan left weeping and wailing. It is said that he wept for forty days.

It is also said that all the idols fell on their faces and the palace of Kisra who was emperor of Persia started shaking and had cracks in it.

Abdul Muttalib saw a white cloud shadowing the house of Sayyida Amina (Pbuh) and ran to enquire. He was told of the birth of Muhammad (Pbuh)

Inspired by Allah, Abdul Muttalib named the child Muhammad. When asked why; he replied that he wished that Muhammad should be praised in the heavens and in the earth (Muhammad means one who is praiseworthy).

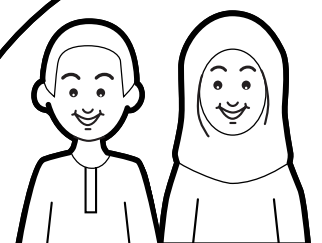

It is said that Sayyida Amina (Pbuh) had named him Ahmed before Abdul Muttalib called him Muhammad.

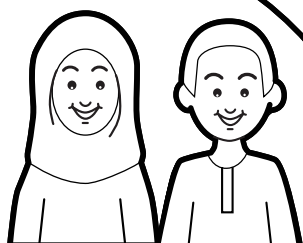

PROPHET MUHAMMAD (pbuh)

It's magic

“The hour drew near and the moon was split apart; and if they see a miracle they turn aside and say: It is magic! ...”

Qur'an - Suratul Qamar - 54:2,3

The people of Makka once came to the Prophet (pbuh) and said:
“If you are a Prophet of Allah, then make the moon split into two!”

The Prophet (pbuh) pointed to the moon and with Allah's help the moon was seen split into two parts.

A man called Ibn Abbas says that he saw the peak of Mount Hira between the two parts of the moon.

The people then asked for the two parts to be joined together and it was done.

They saw the miracle with their own eyes. The Jews who were present became Muslims but the Makkans like Abu Jahl said it was magic and walked away.

The crack is present in the moon even today.

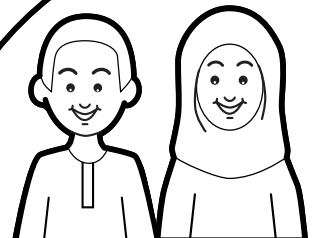
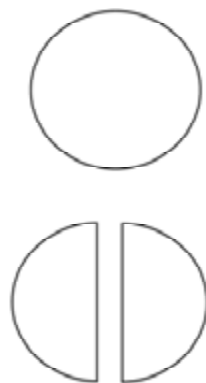

AL-AMIN

(The Trustworthy One)

Once, the Ka'ba was being rebuilt. The people of Makka were all working together to build it.

When the walls reached the level where they had to place the 'Hajar al-Aswad' (The black stone) the work stopped. Everyone wanted to place the black stone in its position because it was so important.

There was a big argument and it seemed like there would be a civil war in Makka.

A wise man spoke out and said:

"Do not make war because it destroys homes and cities. It causes misery and hardship. Find a solution to your problem."

He suggested that they choose a person who would decide what to do from themselves.

The people asked who and how they should choose. The wise man suggested that they appoint the first person who enters Masjid al-Haram through a particular door which he pointed towards.

Everyone agreed and all eyes were fixed on the door.

A young man entered. Everyone was glad for it was Muhammad Al-Amin (Pbuh) (The Trustworthy One). They crowded around him and told him what had happened.

He told them:

"All the leading men of Makka must share in this important work."

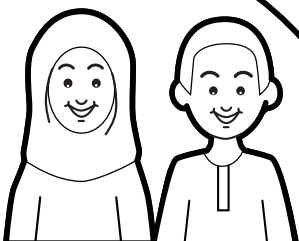

The people looked surprised:

"How is that possible?"

Muhammad (Pbuh) gave instructions for all the leaders of the tribes to be present. When they had all assembled he took off his cloak and placed the Hajar al-Aswad in the middle. He asked all the leaders to pick the cloak and bring it to the side of the Ka'ba.

Muhammad (Pbuh) gently guided the stone to its special place. All the people were pleased. He had not yet declared his prophet hood but even then the people of Makka used to turn to him to settle their differences.

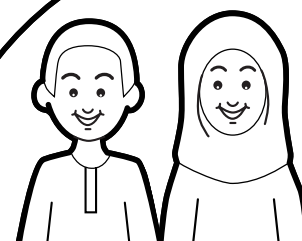

ANNOUNCEMENT OF PROPHETHOOD

As soon as the Prophet (Pbuh) announced that there are no gods but Allah, he was rejected totally. He remained the same person - with the excellent akhlaq but what had changed is that he had declared his belief in Allah.

When he was forty he got the first revelations in the cave of Hira in mountain of Noor (Light) where he used to meditate. It was brought by angel Jibrail and it was the first five ayaat of Suratul Alaq.

"Read in the name of your Lord who created (all);
He created man from a clot of blood;
Read! Your Lord is the most bountiful,
Who by the pen taught man what he did not know".

It was the 27th of Rajab (The day of Be'that) in the 14th year of the life of the Prophet. He was busy in remembrance of Allah in his usual place in the cave of Mount Noor (a mountain situated in the north of Makka). The angel Jibrail came to him and recited to him the above ayaat of the Qur'an. the Prophet had not been taught to read and write by any on earth but his abilities were taught to him by the Lord.

The first person who the Prophet told of this was his wife - Sayyida Khadija. She immediately testified to his Prophethood and gave him her full support.

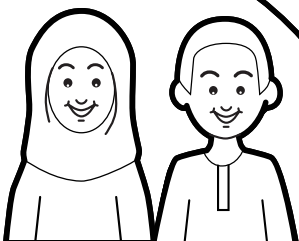

The Prophet began the preaching of his mission to a limited circle for the first three years. Then he was asked by Allah to invite his near relations to Islam.

"And warn your nearest relatives." Qur'an - Suratush Shu'ara 26:214

The Prophet (Pbuh) arranged a meal inviting 40 of his relations. This is known as 'Da'watul Dhul Ashira'. He invited them towards Allah and introduced himself as the Messenger of Allah. He then asked thrice:

"Which one of you will support me so that he may become my brother, wasi and successor after me?"

Each time Imam Ali (Pbuh) who was 15 years old at the time stood up and said:

"O Prophet of Allah! I am prepared to support you !"

The Prophet (Pbuh) held Imam Ali's (Pbuh) hand high and told his audience that Ali (Pbuh) would be his successor and they should listen to him and follow him. The others who were present taunted Abu Talib saying he would now have to take orders from his son. The meeting ended.

After this he began preaching openly to the Quraysh who reacted violently. The Prophet and his followers were constantly harassed. The Prophet was not allowed to worship in the Ka'ba. Thorns were strewn in his path, dirt and filth were thrown at him, he was accused of being a madman, magician and poet and was taunted and insulted. His faithful companions too were tortured. Some were placed on the hot sands and heavy stones were put on their chests, nooses were put round their necks and they were dragged in the streets. The first martyr of Islam was Sumayya, the mother of one of the companions of the Prophet, Ammar Yasir.

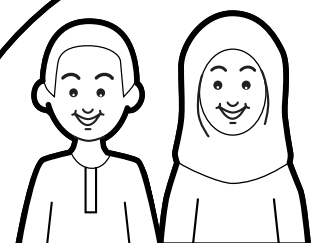

The Prophet had about 100 followers and physical cruelty made life unbearable in Makka. The Prophet advised his followers to go to Abyssinia under the leadership of Jaffer Tayyar. This was the first Hijra in Islam (in the fifth year of Prophet hood) and 15 people took part in it. The Prophet then advised a second Hijra.

When the Quraysh found out that the Muslims were living peacefully in Abyssinia, they sent expensive gifts to the ministers of the King of Abyssinia to bribe them. Then they sent their representative Amr Al-Aas who visited King Najashi (of Abyssinia) asking for the return of the Muslims claiming that they had invented a new religion. The ministers loudly supported the request.

King Najashi asked whether the Muslims had killed anyone, stolen property or committed any crimes. Amr replied that their only crime was the invention of a new religion. King Najashi called Ja'fer bin Abu Talib to the court and asked him why the Muslims had abandoned the religion of their forefathers and started a new religion. King Najashi was impressed with what Ja'fer said and asked him to recite some ayaat from the Qur'an. Ja'fer recited ayaat from Suratu Maryam which moved the King and his ministers. Frustrated that they could not overcome the Prophet, the Quraysh boycotted the families of Hashim and Muttalib, having no contact with them nor allowing food or drink to reach to them. Abu Talib had no choice but to take them to a valley belonging to him called Shib-e-Abu Talib.

For three long years from Muharram in the 7th year after declaration of Prophethood they stayed there under so much hardship that at times they lived on leaves and grass. They came out when the Prophet told Abu Talib that the agreement signed by all the Quraysh to boycott them

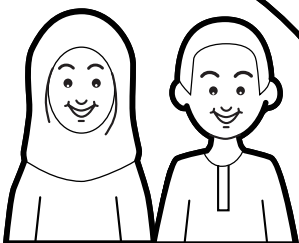

had been eaten up by insects and only the words "In the name of our Lord..." remained. Abu Talib went and told this to the Quraysh who found it to be true and had no choice but to stop their boycott. Shortly after Abu Talib and Khadija both died and this grieved the Prophet so much that he called the year Aamul Huzn (The year of grief).

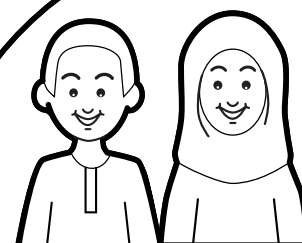

PROPHET MUHAMMAD (pbuh) Me'raj

One night the angel Jibrail came to Prophet Muhammad (pbuh) and said that he was to go on a special journey.

The Prophet (pbuh) rode on a special animal called Buraq which travelled faster than lightning. In Arabic lightning is Barq.

Prophet Muhammad (pbuh) was taken from the Ka'ba to Madina where he was later to go. From there he was taken to Mount Sinai where Prophet Musa (pbuh) had an appointment with Allah for forty nights.

From there he went to Baytulhaam (Bethlehem) where Prophet Isa (pbuh) was born and then to Baytul Muqaddas (Jerusalem) where in the mosque of Aqsa he led Salaatul Jama'a praying with all the other Prophets sent before him.

From Baytul Muqaddas, Buraq took him to the heavens where he met all the other Prophets and saw the places of punishment and the places of blessings.

He also went to the masjid in the heavens.

Allah says in the Qur'an that the Prophet (pbuh) was taken on this special journey so he could see some of the wonderful signs of Allah.

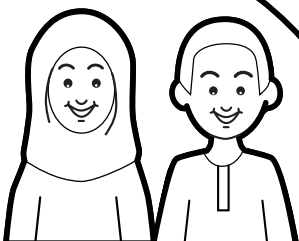

When we have a very good friend we too want to show them our secrets and treasures. Prophet Muhammad (pbuh) is a perfect Muslim who obeyed Allah all the time and so is very close to Allah.

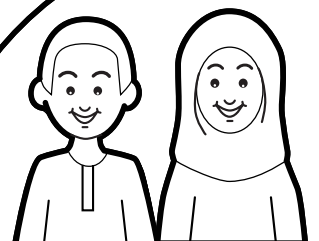

The Prophet went for Me'raj...

When the Prophet went for Me'raj he saw the places of blessings and the places of punishment.

Connect the bad deeds with the place of punishment and the good deeds with the place of blessing.

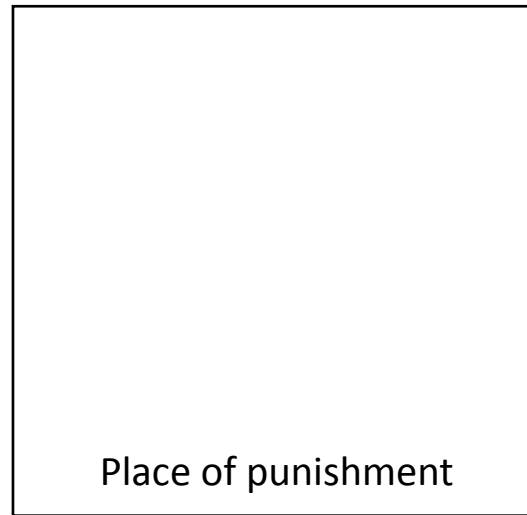
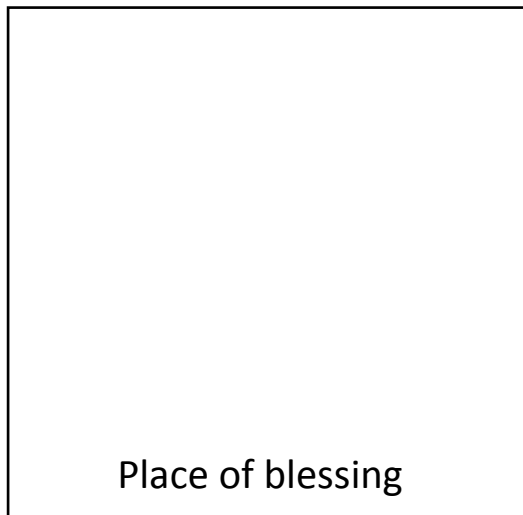

Salaa (Namaz)

Lying

Naughty

Sawm(Fasting)

Reciting Qur'an

Fighting

Being rude

Learning

Doing assignment

Watching too much TV

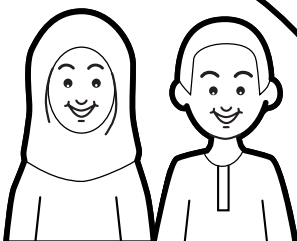

PROPHET MUHAMMAD (pbuh)

Hijra to Madina

The people of Makka who did not believe in Allah had tried everything. They tried to stop the Prophet (pbuh) from believing in Allah by offering him riches and comfort but that did not work. They tried to be nasty to him and his followers but that too did not work so they decided to kill him. They chose one person from each tribe to meet one night and kill the Prophet (pbuh) whilst he was sleeping.

Allah had told the Prophet (pbuh) of their plan through the angel Jibrail. The Prophet (pbuh) asked Imam Ali (pbuh) to sleep in his bed that night. On hearing the request Imam Ali (pbuh) immediately did a sijda of shukr to thank Allah for having given him the honour of protecting the Prophet (pbuh).

The Prophet (pbuh) recited some ayaat of Suratu Yaseen and slipped out of the house under the very noses of the killers. Imam Ali (pbuh) had never slept more peacefully.

Later in the night, the killers burst into the house. They lifted the blanket to find Imam Ali (pbuh) sleeping in the Prophet's (pbuh) place.

Their plan had failed.

Prophet Muhammad (pbuh) was on his way to Madina where the people had invited him to come.

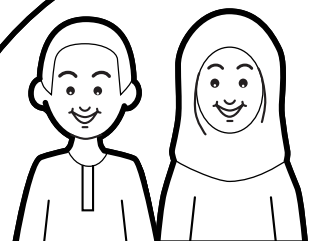

FAREWELL HAJJ

Since the time when Prophet Ibrahim (Pbuh) had built the Holy Ka'ba, it had been a place of worship. Over the years, this worship had deteriorated into strange and undesirable practices. People used to dance naked around the Holy Ka'ba, and they had put idols inside it.

Even after the conquest of Mecca when these idols were broken, the people did not know how to perform the Hajj ceremonies properly. The Prophet (Pbuh) therefore performed Hajj in 10 A.H., so that the people would remain in no doubt as to how it should be done.

He could also instruct the people about the boundaries of Mina and Arafat and teach them about the times of departure from these places.

In Dhulqa'da he announced that he was going to perform the Hajj that year.

Thousands gathered outside Madina awaiting the departure of the Prophet (Pbuh).

The Prophet (Pbuh) appointed Abu Dajana as his representative in Madina and proceeded toward Makka taking with him 60 animals for sacrifice.

At Zil Hulaifa, in the mosque of Shajara, he put on his Ihram.

At Arafat, the Prophet (Pbuh) whilst mounted on his camel, delivered his famous and historical speech to the thousands of people who had gathered. He addressed the people and went through a summary of his teachings to them. He repeated all the major and minor elements of

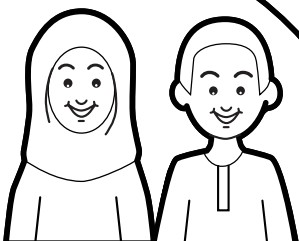

Islamic principles so that there could be no doubt left in their minds. When he finished he offered his noon and afternoon prayers with 100,000 men.

The Prophet (Pbuh) then completed the Hajj

This Hajj is known as Hajjatul Wida (the Farewell Hajj) because it was the last Hajj that the Prophet (Pbuh) performed in his life. During this Hajj he demonstrated every feature of the ceremony, so that there could be no confusion later.

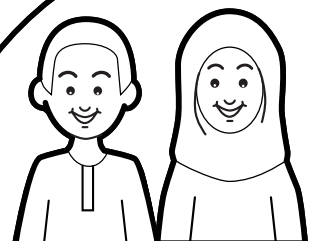

A VERY SPECIAL ANNOUNCEMENT

It was a hot sunny day.

Lots and lots of people were coming back from Makka after doing hajj with the Prophet (Pbuh).

They stopped at a place near Johfa which was known as Ghadeer e Khum.

The angel Jibraail came and told the Prophet (Pbuh) that he had a special announcement for the Prophet (Pbuh) to make to the people.

The Prophet (Pbuh) asked Bilal to give the adhaan. Bilal had a beautiful voice and he was the Prophet's favourite muadhin (Someone who gives adhaan). When the people heard the adhan, they all came to hear the Prophet (Pbuh). Even those who had gone forward came back.

After the Dhuhur salaa, Prophet Muhammed (S.A.W) stood on a pulpit made out of saddles.

He told the people that he was soon to die. He was leaving behind two very important things which the Muslims should always follow:
The Quran and The AhlulBayt.

He then held the hand of Imam Ali (Pbuh) high up and told the people that as per the command of Allah, Imam Ali (Pbuh) would be the leader of the Muslims after him. He said:

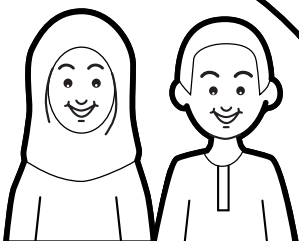

مَنْ كُنْتُ مَوْلَاهُ فَهَذَا عَلِيٌّ مَوْلَاهُ

For whosoever I am the mawla (master), Ali is his mawla (master).

He repeated this three times.

As soon as he had announced this, Jibraail brought another message from Allah which said that Islam was now complete and perfect. This was the last aya of the Qur'an to be revealed. It is aya 3 of Suratul Ma'ida.

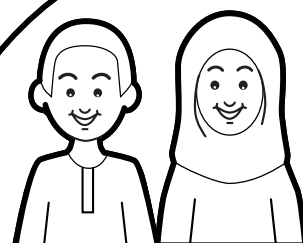

PROPHET MUHAMMAD (pbuh) Salaa! Salaa!

In the Muharram of the year 11 A.H. Prophet Muhammad (pbuh) became very ill.

Three days before he died he asked for a paper, pen and ink so he could write some advice for the Muslims so that they would always stay on the right path.

One of his companions, Umar who was there refused to give him what he had asked for saying that the Qur'an was enough and that the Prophet (pbuh) was sick and did not know what he was saying. The Prophet (pbuh) got angry and sent him away.

On the 28th of Safar 11 A.H. Prophet Muhammad (pbuh) died with his head resting in the lap of Imam Ali (pbuh)

The last thing he said was:
Salaa! Salaa!!

Imam Ali (pbuh) gave him ghusl and kafan and it was he who buried him in his house which was joined to the mosque of Madina.

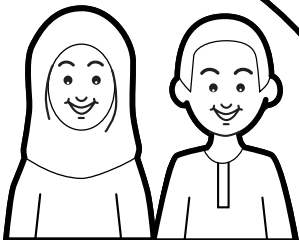

SAYYIDA FATIMA AZ-ZAHRA (pbuh)

Sayyida Fatima Az-Zahra (pbuh) is the daughter of Prophet Muhammad (pbuh) and Sayyida Khadija (pbuh)

She was born in Makka on the 20th of Jamad ul Aakher.

Her mother died when she was only 5 years old.

The people of Makka used to laugh and throw things at her father - Prophet Muhammad (pbuh) because he taught that there was no god except Allah. She used to help her father brush the rubbish off his clothes.

Whenever she entered a room where the Prophet (pbuh) was, he used to stand up out of respect for her.

The Prophet (pbuh) gave her a gift - Tasbeeh of Sayyida Fatima Az-Zahra (pbuh) to recite:

34 times 'Allahu Akber'

33 times 'Alhamdulillah'

33 times 'Subhanallah'

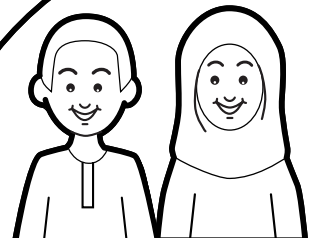

She got married to Imam Ali (pbuh) and they had five children:

Imam Hasan (pbuh)

Imam Husayn (pbuh)

Sayyida Zaynab (pbuh)

Sayyida Umme Kulthum (pbuh)

Baby Muhsin (pbuh) - who died in his mother's womb

After the Prophet (pbuh) died, the bad rulers tried to burn down her house and even pushed a door down on her. She was hurt badly and this is when baby Muhsin (pbuh) died in her tummy.

She died soon after. Imam Ali (pbuh) was very sad. He buried her at night so nobody could find her grave to trouble her any more.

She is buried in Madina.

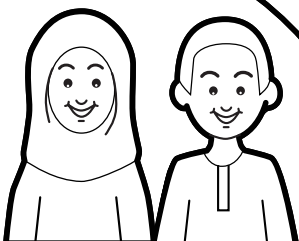

Family Tree of ESkk[VS Fatima Zahra (pbuZfi

Fill in the blanks of the family tree.

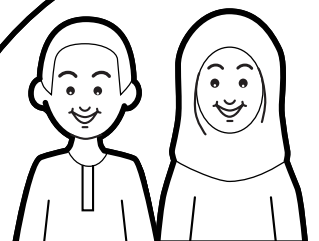
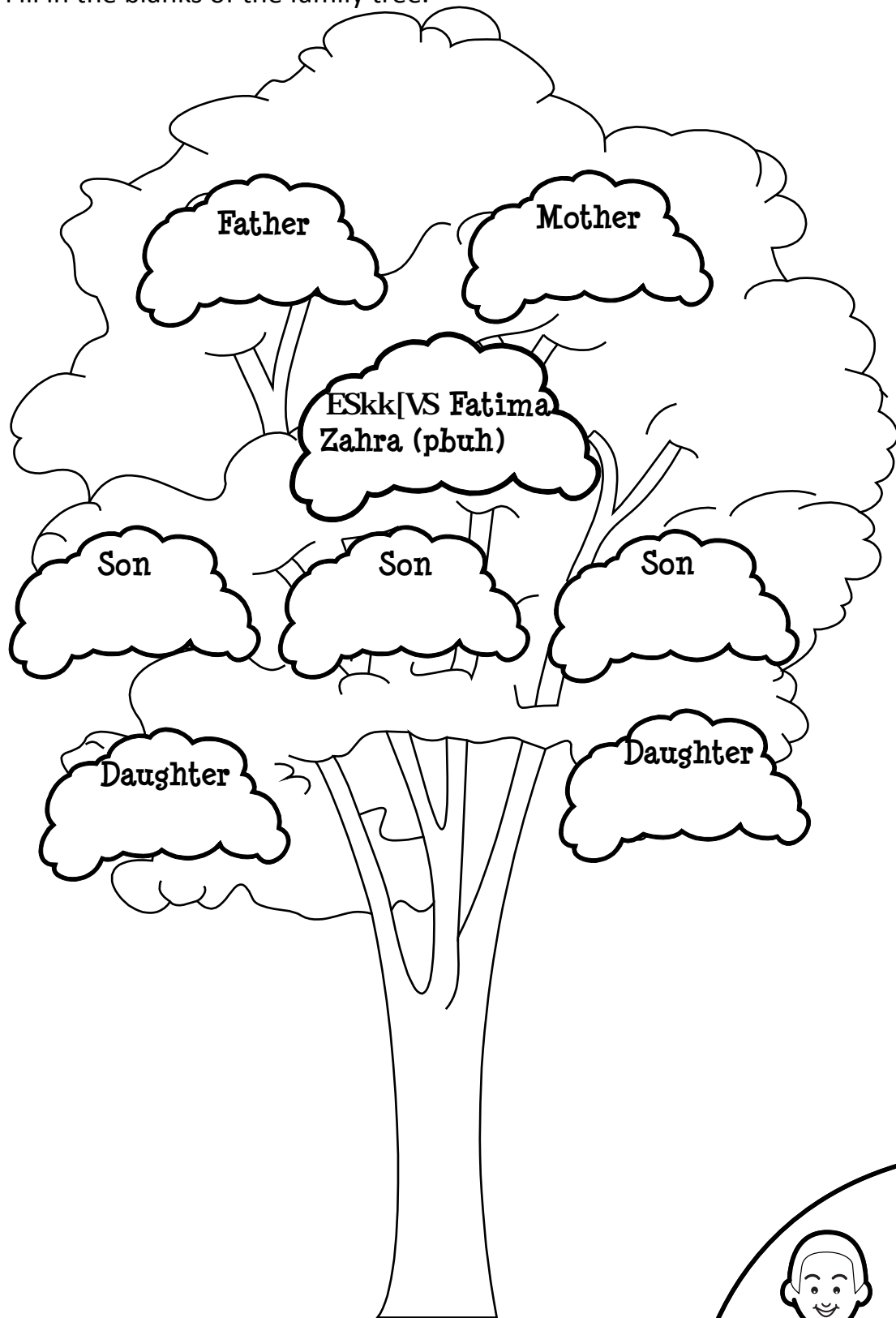

The tasbeeh of Sayyida Fatima Zahra (pbuh)

Tasbeeh of Bibi Fatima Zahra (pbuh)

Draw 34 beads for 'Allahu Akber'

33 beads for 'Alhamdulillah'

33 beads for 'Subhanallah'

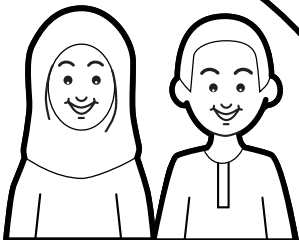
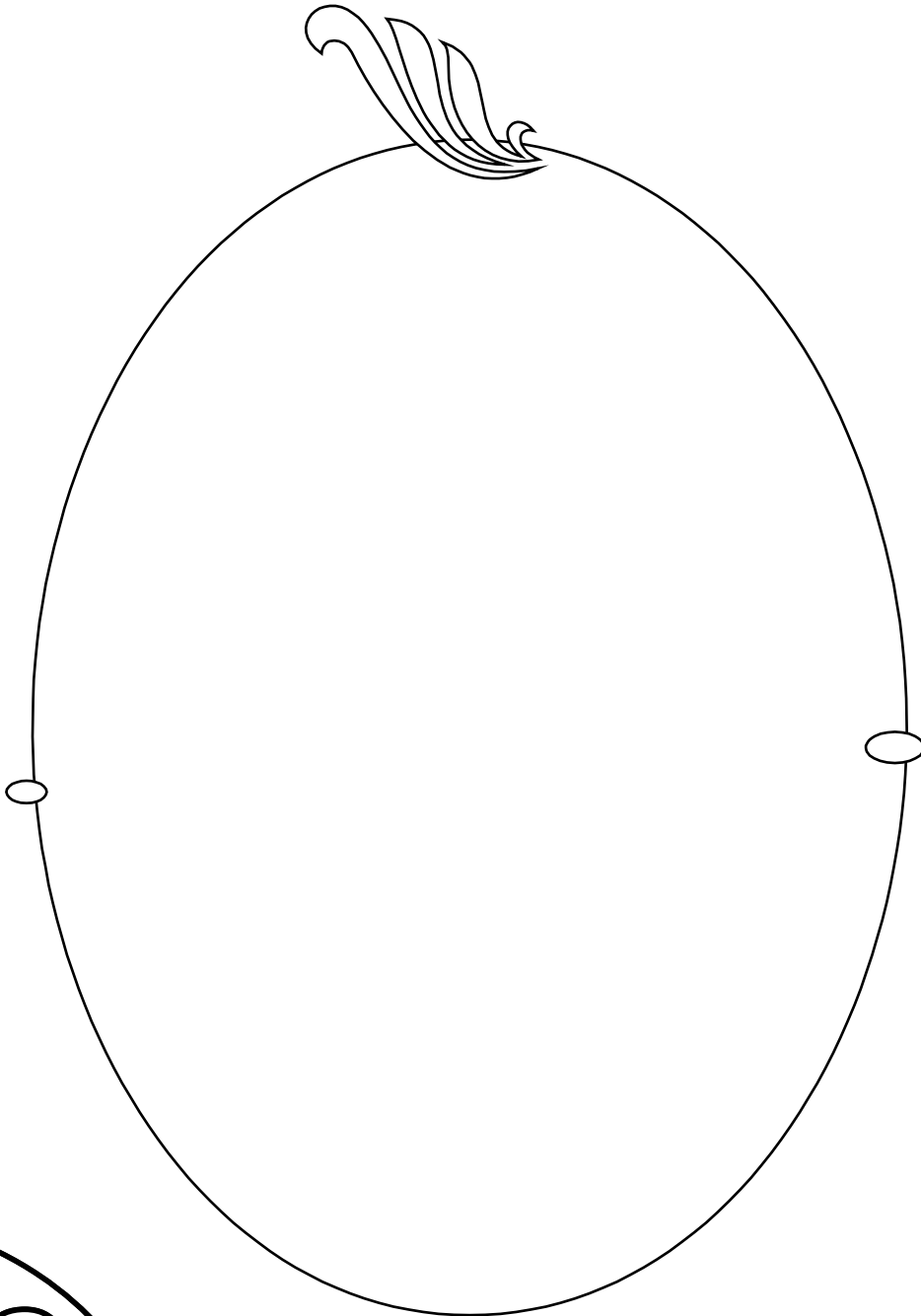

1 - IMAM ALI (pbuh)

He was born in the Ka'ba in Makka on the 13th of Rajab - the year 30 'Aamul Feel.

His father was called 'Imran but is better known as Hazrat Abu Talib (pbuh)

His mother was Sayyida Fatima binte 'Asad (pbuh)

He was a very brave man and the hero of all the battles of Islam. He had a special sword called Zulfikar.

He was very clever. The Prophet (pbuh) said:
"I am the city of knowledge, and Ali is its gate"

When Imam Ali (pbuh) was 22 years old, the Prophet (pbuh) went from Makka to Madina because the bad people of Makka wanted to kill him. Imam Ali (pbuh) slept in the Prophet's bed so that the bad people would not know that he had left.

He married the Prophet's daughter - Sayyida Fatima Az-Zahra (pbuh) and they had five children.

The Prophet (pbuh) on Allah's command had chosen Imam Ali (pbuh) as the leader (Imam) of the Muslims after him.

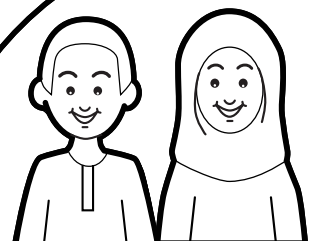

On the 19th of Ramadhan 40 A.H. in the masjid of Kufa a bad man called Abdur Rahman ibn Muljim hit him on the head with a poisonous sword. Imam Ali (pbuh) died two days later.

He is buried in Najaf (Iraq).

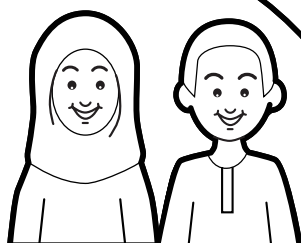

Activity Sheet - Imam Ali (pbuh)

Match the columns

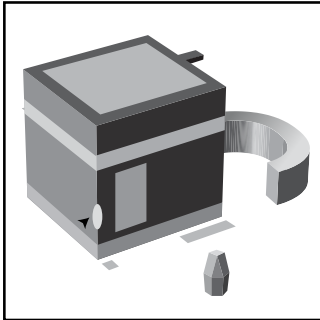

Asadullah which means
..... of Allah

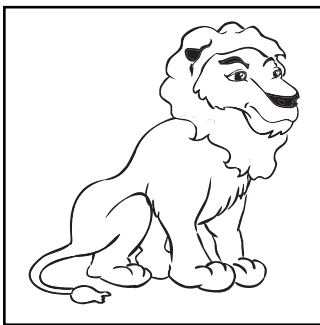

He was born here

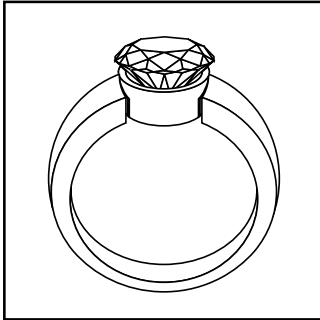

Zulfikar

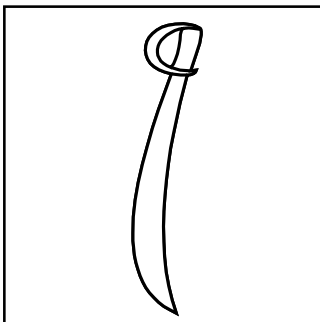

He gave this in ruku
to a poor man

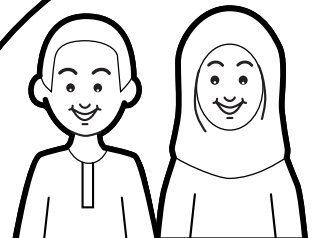

2 - IMAM HASAN (pbuh)

He was born in Madina on the 15th of Ramadhan 3 A.H.

His father is Imam Ali (pbuh) and his mother is Sayyida Fatima Az-Zahra (pbuh)

He is the first grandchild of the Prophet (pbuh). When the Prophet (pbuh) heard of the birth of Imam Hasan (pbuh) he was very happy.

When Imam Hasan (pbuh) was 7 days old, the Prophet (pbuh) arranged for his hair to be shaved off. The hair was then weighed against silver which was then given to the poor. An animal was also sacrificed. The Prophet (pbuh) also arranged for a feast for all the people of Madina. This ceremony is called 'aqeeqa'.

When Imam Hasan (pbuh) was older, he always went to listen to the lectures of the Prophet (pbuh) in the Masjid. When he came home from the masjid his mother would ask him about the lecture, and he would relate to her whatever the Prophet (pbuh) had said.

Whenever he went to do Wudhu, he used to tremble and his face went pale. When he was asked why - he answered:
"Do you not know that I am standing in front of Allah?"

There was a bad man called Muawiyah who said bad things about Imam Hasan (pbuh). He also paid people to be the enemies of Imam Hasan

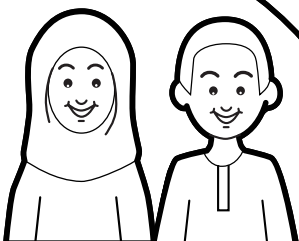

(pbuh). He even gave money to Imam Hasan's wife so that she would poison him.

Imam died of the poison that his wife Juhda gave him.

He died on the 7th of Safar 50 A.H.

He is buried in Jannatul Baqee in Madina.

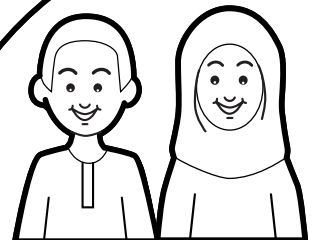

Imam Hasan (pbuh)

Fold a piece of card and draw a heart on the front cover.
Write Imam Hasan (pbuh) on it. Colour and decorate the heart.

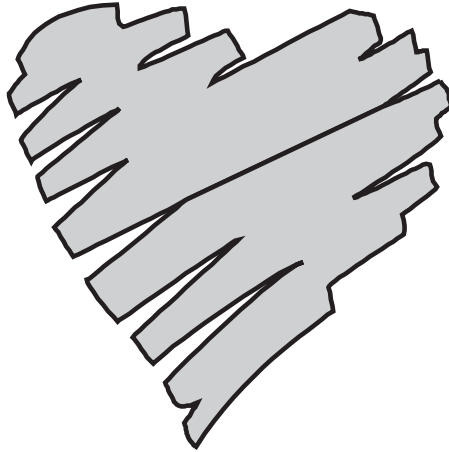

Write a greeting inside the card.
e.g.

In Hadithe Kisaa, Sayyida
Fatima Zahra (pbuh)
addressed her son Imam
Hasan (pbuh) as "Thamarata
fuaadiy" - Dlight of my heart

To,
My dearest Mummy & Papa,

On this day I promise that I
Will try my best to follow the
teachings of my Imam and I
hope always to remain your
thamarata fuaadiy.

Lots & Lots of Love & Duas



3 - IMAM HUSAYN (pbuh)

Imam Husayn (pbuh) was born in Madina on the 3rd of Sha'ban 4 A.H.

His parents are Imam Ali (pbuh) and Sayyida Fatima Az-Zahra (pbuh).

On the day he was born, Allah told the angel Jibraail to go and congratulate the Prophet (pbuh), Imam Ali (pbuh) and Sayyida Fatima Az-Zahra (pbuh). On the way down from the heavens, Jibraail passed an island where the angel Fitrus was banished to (as a punishment for taking too long in doing something Allah had ordered him to do). His wings had also been taken away.

“Where are you going, Jibraail?” Fitrus asked.

Jibraail told him he was going to congratulate the Prophet (pbuh) and his family on the birth of Imam Husayn (pbuh)

“Can I come with you?” Fitrus asked

With Allah's permission, Jibraail took Fitrus with him. They congratulated the Prophet (pbuh).

The Prophet (pbuh) asked Fitrus to touch the cradle of Imam Husayn (pbuh). As soon as he touched the cradle, with the permission of Allah his wings were restored. He thanked the Prophet (pbuh) When Fitrus returned to the heavens; all the other angels asked him what perfume he had used because there was a fragrance coming from him. Fitrus replied:

“I am the lucky one who has touched the cradle of Imam Husayn (pbuh).”

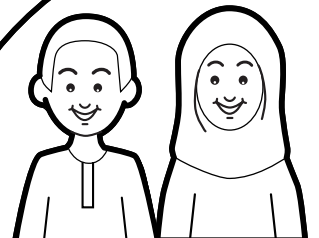

Prophet Muhammad (pbuh) loved Imam Husayn (pbuh) and he said that there would come a day when Imam Husayn (pbuh) would save Islam.

Yazid was an evil man who became the ruler of the Muslims. He tried to change everything that the Prophet (pbuh) had taught. He even dressed monkeys like 'ulema (learned people) and sat them on the mimbar of the Prophet (pbuh). He killed anyone who did not obey him. Yazid wanted Imam Husayn (pbuh) to promise to obey and follow him. When Imam refused, he became very angry.

Yazid got a large army together and surrounded Imam Husayn (pbuh) and his family and friends in Karbala.

On the day of 'Ashura 61 A.H., Imam Husayn (pbuh), his friends and male family members including baby Ali Asgher who was 6 months old were killed. The women, children and Imam Ali Zaynul Aabedeen (pbuh) who was ill were taken prisoners.

Imam Husayn (pbuh) and the other shuhada (martyrs - those killed in the way of Allah) are buried in Karbala.

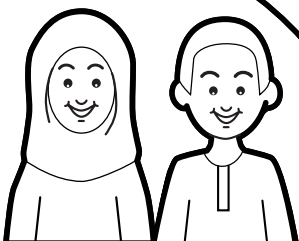

Imam Husayn (pbuh)

Draw a tablet of clay under the boys head.

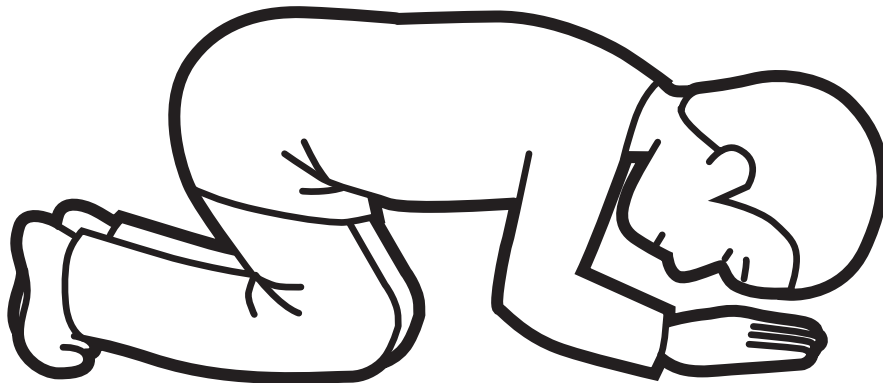

Khak e Shifa

Find where Kerbala is on the map and mark it on the map.

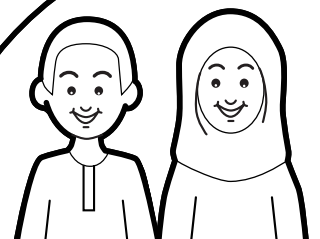

**“If this world be considered a
treasure, then a reward far better is
Allah’s pleasure...”
Imam Husayn (pbuh)**

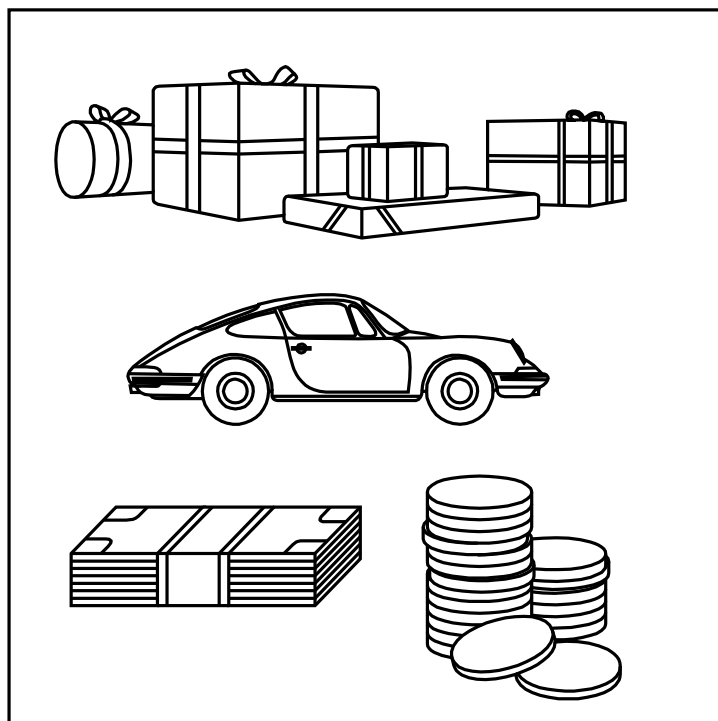

How would you use the things above to get Janna?

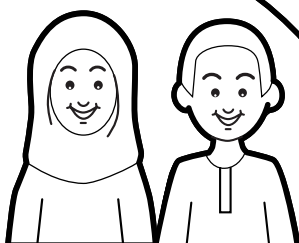

4 - IMAM ALI ZAYNUL AABIDEEN (pbuh)

Imam Ali Zaynul Aabideen (pbuh) was born in Madina on the 5th of Sha'ban 38 A.H.

His father is Imam Husayn (pbuh) and his mother was a princess from Iran. Her name was Sayyida Shahrbanu.

He was given the title 'Zaynul Aabideen' which means the 'best of worshippers'. He is also called 'Sayyidus Saajideen' meaning 'one who is the leader of those who do sijda'.

After the day of 'Ashura, when his father, uncles, cousins, brothers and friends were killed in Karbala, he was taken prisoner along with all the women and children of Ahlulbayt. He was tied in chains and a spiked collar was put around his neck. He was made to walk behind the camels which carried the women and children prisoners through towns and villages from Karbala to Kufa to Shaam (Damascus) where Yazid was.

Even though Imam was beaten and tied up, he told Yazid what a bad man he was and that Allah would punish him for his sins.

The prisoners including Imam Ali Zaynul Aabideen (pbuh) were put in a prison in Shaam which had no roof. It was very hot during the day with no shade from the sun and very cold at night with no blankets to keep them warm.

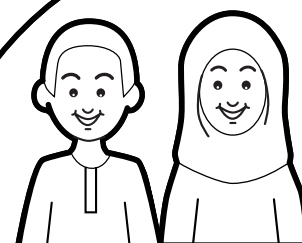

When he was freed from prison, Imam told everyone about Islam and standing up for the truth even if it means giving your life. He did this by holding and encouraging the majalis of Imam Husayn (pbuh). He also wrote a book of duas which is called 'Sahifatus Sajjadiyya' or 'Sahifatul Kamila'.

He was poisoned by the bad ruler Waleed and he died on the 25th of Muharram 95 A.H.

He is buried in Jannatul Baqee in Madina.

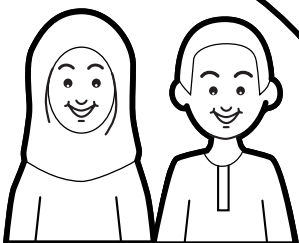

Imam Zaynul Abideen (pbuh)

Match the columns below:

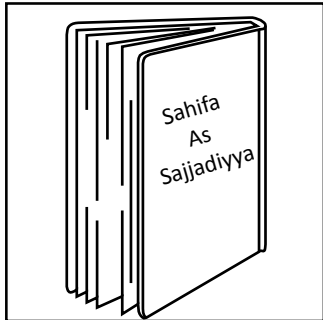

Father

Imam Husayn
(pbuh)

Mother

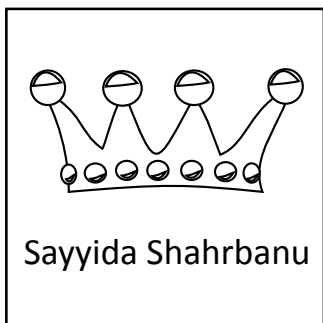

Title

Zaynul Abideen

Book of Duas
He wrote

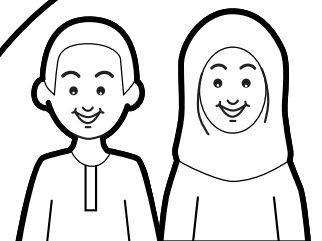

5 - IMAM MUHAMMAD AL-BAQIR (pbuh)

He was born in Madina on the 1st of Rajab 57 A.H.

His father is Imam Ali Zaynul Aabideen (pbuh) and his mother was Sayyida Fatima bint Al-Hasan (pbuh) (She was the daughter of Imam Hasan (pbuh))

He was 3 years old in Karbala and was taken as prisoner with the women and children of the family of the Prophet (pbuh)

Imam was called Baqir al Uloom which means one who splits open knowledge, he taught many students.

He was the first to start writing books of Fiqh.

Although he was an Imam he still worked hard in the fields under the hot sun.

The ruler of the time wanted an idea of what to write on the coins of that country called Deenar which was the money of that time. Imam Muhammad Al-Baqir (pbuh) advised him to write:

لَا إِلَهَ إِلَّا اللَّهُ - 'There is no god except Allah' on one side and

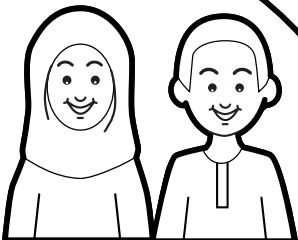

مُحَمَّدٌ رَسُولُ اللَّهِ - 'Muhammad is the messenger of Allah' on the other side.

The bad ruler of the time called Hisham sent Imam a poisoned saddle as a present. When Imam sat on it, the poison went into his body and he died on the 7th of Dhulhijja 114 A.H.

He is buried in Jannatul Baqee in Madina.

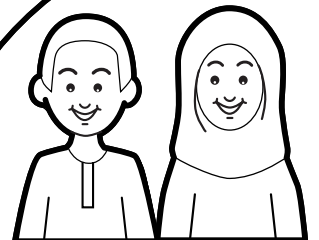

Imam Muhammad Al-Baqir (pbuh)

Colour the correct batteries which will produce the light of knowledge.

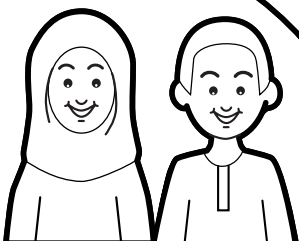
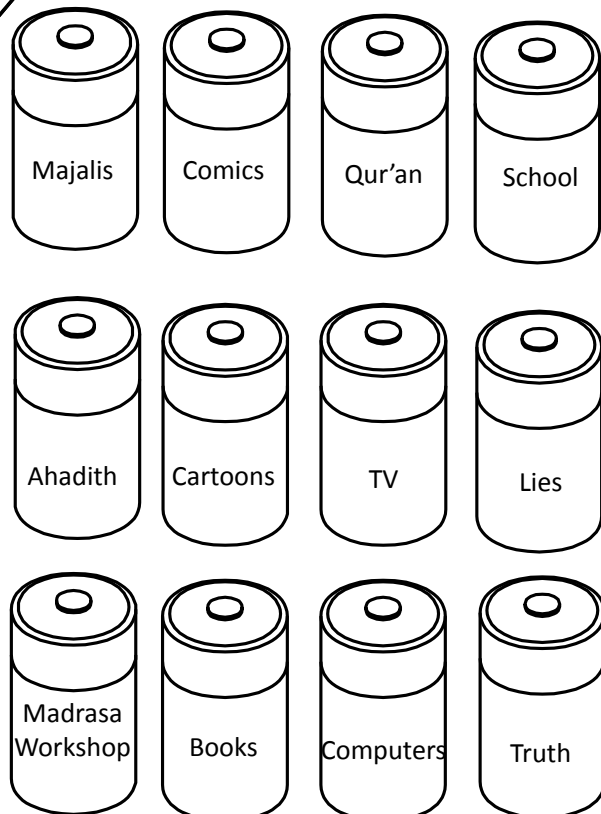
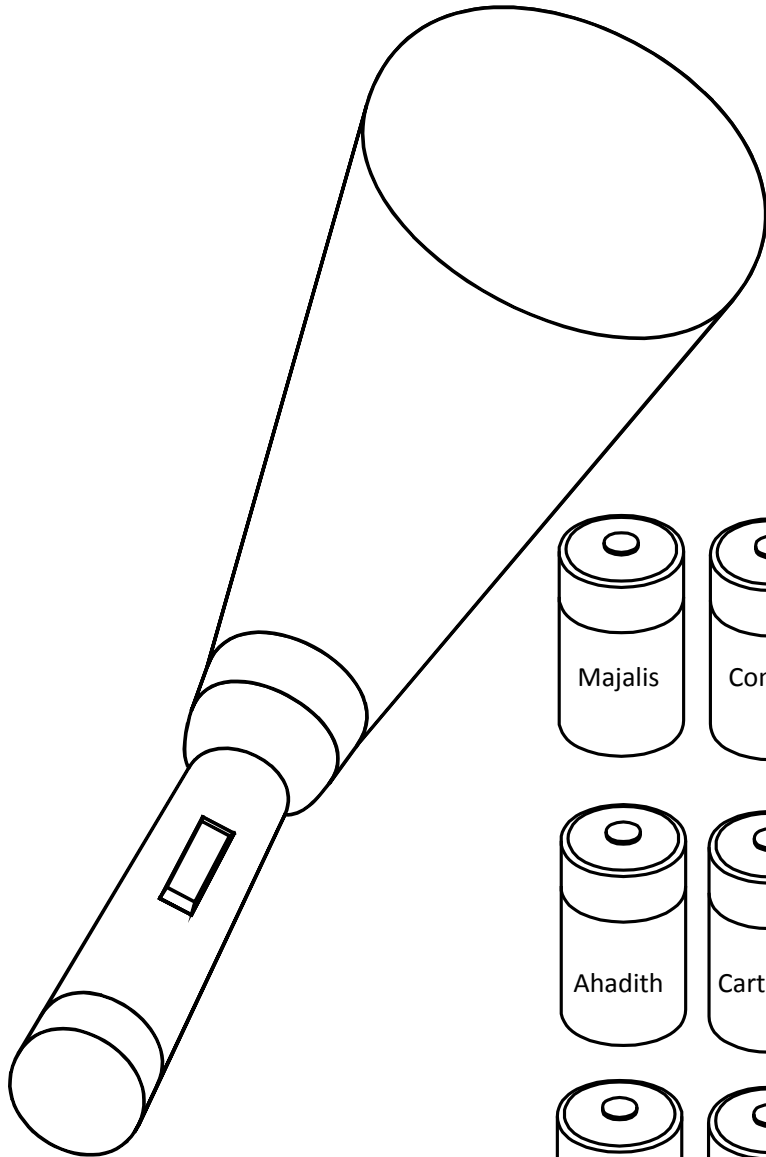

Knowledge...

How do you increase your knowledge?
Circle the answers

Madrasa

School

Watching
TV

Qur'an Classes

Parties

Majalis

Reading good
books

Reciting
Qur'an

Teaching

Observing
others

Computer
games

Shopping

Fighting

Discussing

Sleeping

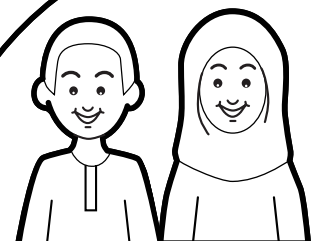

6 - IMAM JA'FER AS-SADIQ (pbuh)

Imam Ja'fer As-Sadiq (pbuh) was born in Madina on the 17th of Rabi ul Awwal 83 A.H. He has the same birth date as Prophet Muhammad (pbuh)

His father is Imam Muhammad Al-Baqir (pbuh) and his mother was Sayyida Fatima better known as Umme Farwa. She was a very clever lady who taught the laws of Islam.

After Imam Muhammad Al-Baqir (pbuh) was poisoned the bad rulers were busy fighting each other and this allowed Imam Ja'fer As-Sadiq (pbuh) to open schools (madrasas) without any interference.

He taught many subjects including medicine, chemistry, geography, fiqh (laws of Islam), and explanation of the Qur'an.....

He had some very clever students like Jabir bin Hayyan who is known today as the 'Father of Chemistry'. Jabir always started his writings with "...I have learnt this from my master Ja'fer As-Sadiq (pbuh)....."

We are known as Ja'fery because we are the followers of the Fiqh (laws of Islam) as compiled by Imam Ja'fer As-Sadiq (pbuh).

When Imam was 65 years old, a bad ruler called Mansur sent him poisoned grapes.

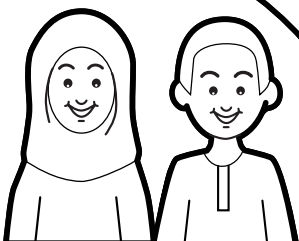

Imam died on the 25th of Shawwal 148 A.H. and is buried in Jannatul Baqee in Madina.

One of the companions of Imam - Abu Baseer went to the house of Imam to give his condolences to the family after Imam had died. Imam's wife - Sayyida Umme Hameeda was very sad. She told Abu Baseer that just before Imam had died he called his family members close to him and said:

“Those who take salaa lightly will not get our shafa'a (intercession)”

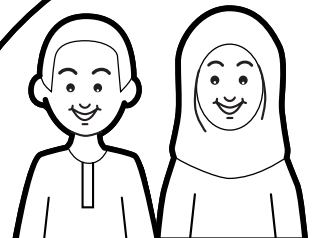

Imam Ja'fer As-Sadiq (pbuh)

Jabir Ibn Hayyan (known as Geber) who is the Father of Chemistry learnt from Imam Ja'fer As-Sadiq (pbuh)

Join the dots and colour the picture

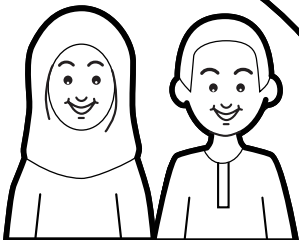
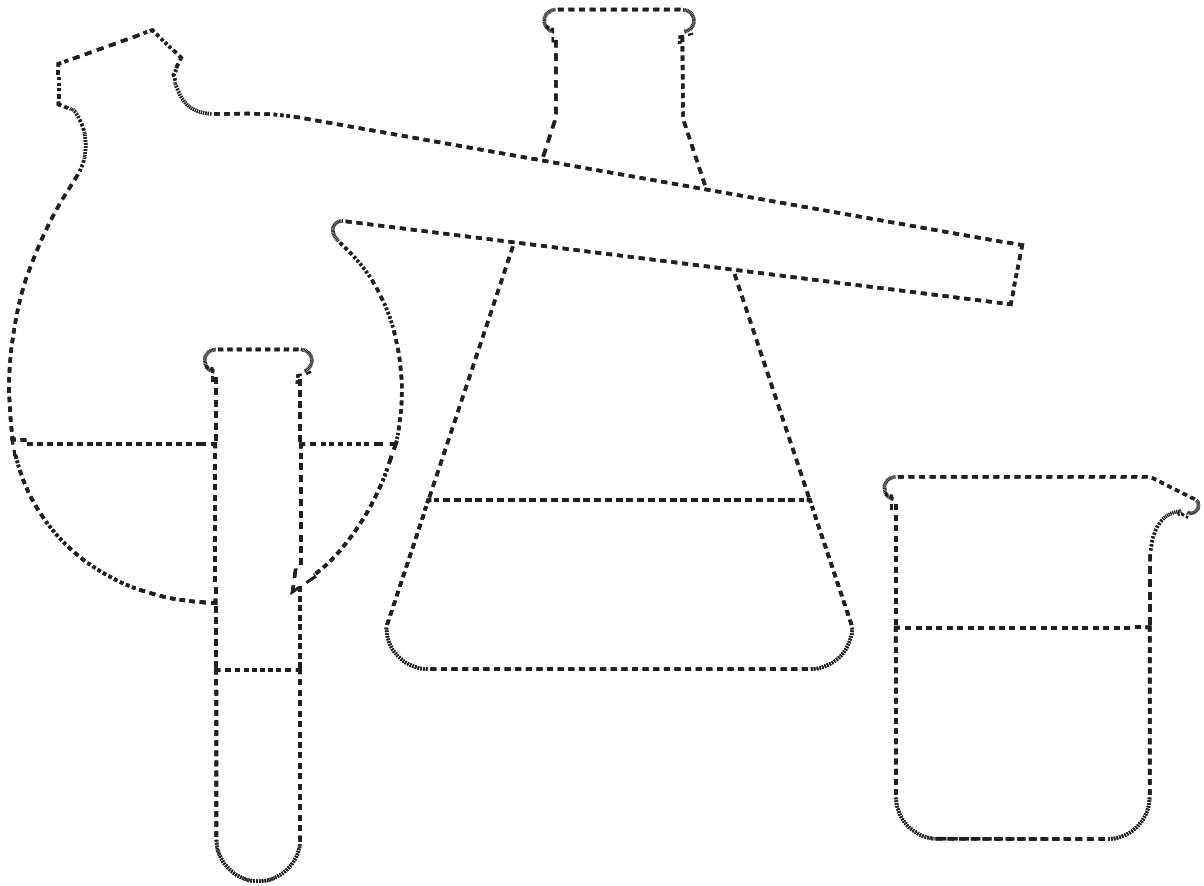

Imam Ja'fer As-Sadiq (pbuh)

Match the columns below:

Number of students
taught by Imam

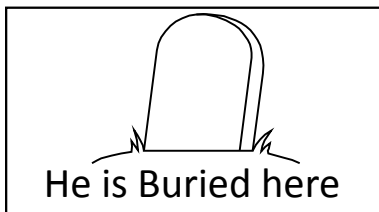

Imam Muhammed
Al- Baqir (pbuh)

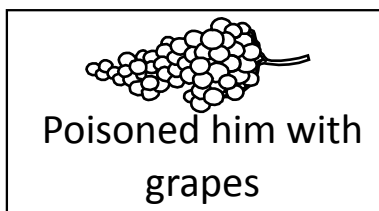
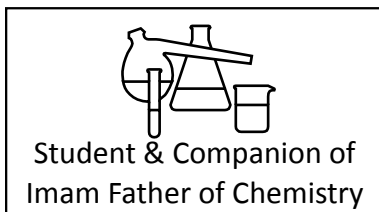

Umme Farwa

His Father

Jabir Ibn Hayyan

Mother

Mansur

4000

Jannatul Baqee

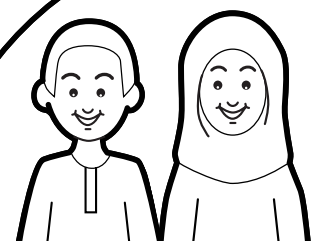

7 - IMAM MUSA AL-KADHIM (pbuh)

He is the son of Imam Ja'fer As-Sadiq (pbuh) and Sayyida Hameeda.

He was born on the 7th of Safar 128 A.H. Because Safar is a sad month we celebrate his wiladat (birthday) on the 7th day of the 7th month (As he is our 7th Imam).

He was born in Abwa which is a place between Makka and Madina. Prophet Muhammad's (pbuh) mother - Sayyida Amina is buried there.

He was given the title Al-Kadhim which means 'someone who swallows his anger'. One who does not show his/her anger is patient. Like all the other Aemma, he too could speak with wisdom from birth.

Once when Imam was 5 years old, a visitor of his father saw the young Imam with a lamb telling the lamb to bow down saying:
"Bow down to the One who made you."

A bad ruler called Harun Rashid put Imam in prison for 19 years. The prison was so small that Imam could not even stretch his legs. He was given only 2 pieces of dry bread and a glass of hot water per day.

The same bad ruler killed the Imam by giving him poisoned dates. Imam died in Baghdad on 25th Rajab 183 A.H.

He is buried in Kadhmain - a part of Baghdad (Iraq).

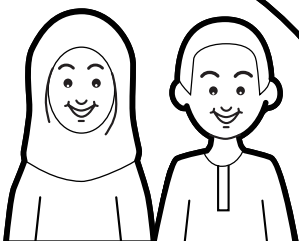

Imam Musa Al-Kadhim (pbuh)

He is our 7th Imam born on the 7th of Safar so we celebrate his wiladat on the 7th of the 7th month.

Join the dots to find the name of the 7th month.

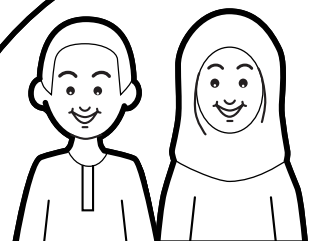
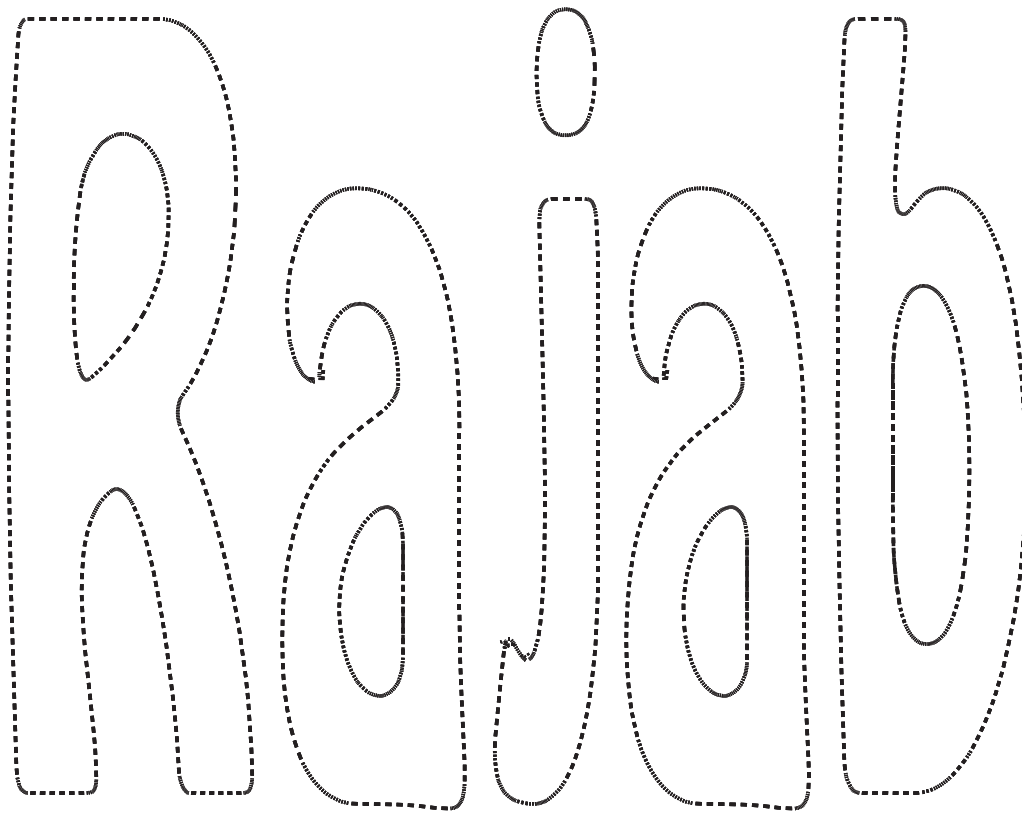

Al-Kadhim

The one who swallows anger

Draw a cross on the one who is angry.

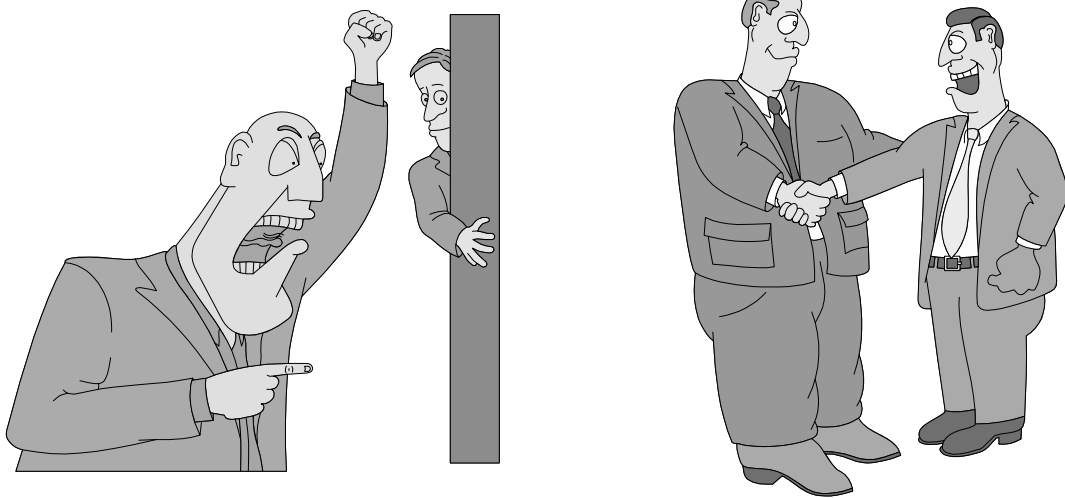

Draw a happy face and an angry face in the circles below.

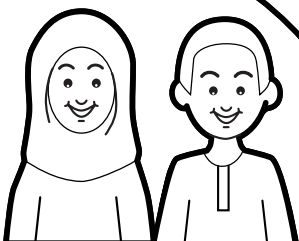
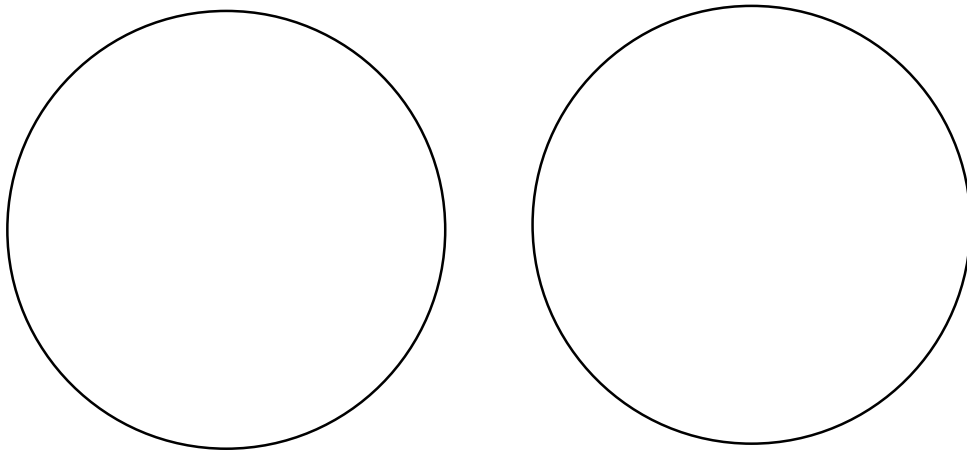

8 - IMAM ALI AR-RIDHA (pbuh)

Imam Ali Ar-Ridha (pbuh) was born in Madina on the 11th Dhulqa'da 148 A.H.

His father is Imam Musa Al-Kadhim (pbuh) and his mother was Sayyida Ummulbanin Najma.

His grandfather Imam Ja'fer As-Sadiq (pbuh) used to tell his companions to await the birth of his grandson who would be very clever and known as 'Aalim aali Muhammad' - the learned one from the household of the Prophet (pbuh).

He was also known as Imam Zaamin (pbuh). Zaamin means safety. One day Imam was walking through the market place when he saw a hunter about to kill a deer. The deer was struggling. When the deer saw Imam she said something to him which he understood. Imam asked the hunter to free her so that she could feed her little ones who were hungry. The deer would then return to the hunter. The hunter thought Imam was making a fool of him, so Imam stood with the hunter until the deer came back with her young ones. She asked Imam to look after them.

The bad ruler Mamun had ordered that nobody was allowed to visit Karbala for Ziyara. Anybody who dared to go was killed. When Mamun forced Imam to become the heir apparent (to be ruler after him) just to become popular with the people, he said those who got a safety order from Imam Ali Ar-Ridha (pbuh) could go for Ziyara to

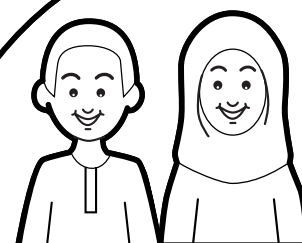

Karbala. Imam encouraged the Ziyara and gave safety orders to who so ever wished to go.

When Mamun saw that Imam was becoming more popular than him he invited him one evening and gave him poisoned grapes.

Imam died on 29th Safar 203 A.H.

He is buried in Mash'had in Iran. He is also known as 'Gharibul Ghuraba' meaning one who is a stranger and far from family and home (Imam's home was in Madina).

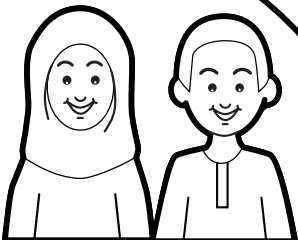

Poem - Imam Ali Ridha (pbuh)

To the hunter with the deer,
Said my Imam "Have no fear",

"Let her feed her kids,
She'll return to you after seeing to their needs",

"I'll stand in her place,
I promise you'll not lose face",

The deer returned as promised by Imam,
Safely to the hunter who became calm.

Imam is the surety
To ward off calamity.

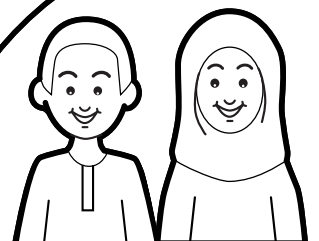

Hadith of the golden chain

Write the names of the Prophet (pbuh) and A'imma upto Imam Ridha (pbuh) preferably with gold glitter on strips of paper.

Make a paper chain and connect it to some wings with Jibraeel written on them and then to a circle with Allah on it.

Connect the bottom of the chain to a FORT with Laa Ilaha Illallah written on it.

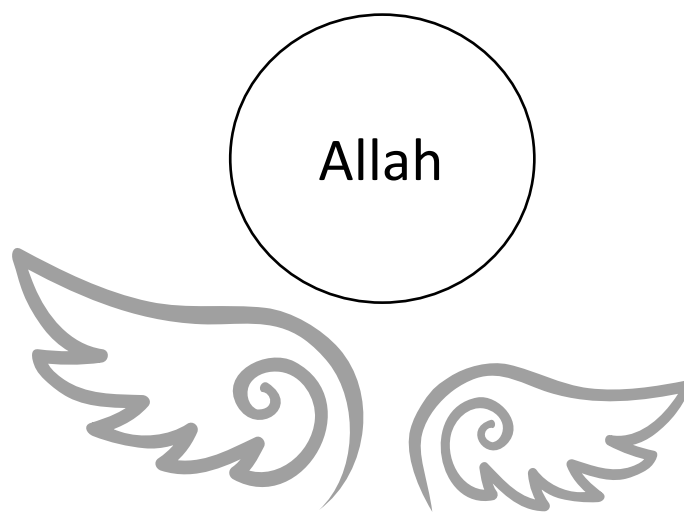

Allah

Jibraail

Name of Ma'sum

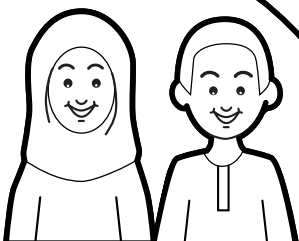

9 - IMAM MUHAMMAD AT-TAQI (pbuh)

He is the only son of Imam Ali -Ar-Ridha (pbuh)

His mother was Sayyida Sabika Khaizarun.

He was born on the 10th of Rajab 195 A.H. in Madina.

One day when he was 5 years old, he was with some other children. The bad ruler Ma'mun who had poisoned his father passed by in his carriage. All the other children ran away but Imam stayed.

Mamun stopped his carriage and asked the young Imam why he was standing there. Imam told him that the road was wide enough for all of them and he had not done anything wrong. Ma'mun asked him who he was. When Imam told him that he was the son of Ali Ar-Ridha (pbuh) Ma'mun asked him if he knew what was in Ma'mun's hand (Ma'mun was hiding a tiny fish in his hand).

Imam said:

“Allah has made tiny fish in the rivers. These fish are hunted by the rulers and it is the Aimmah who reveal the secrets of the rulers.”

Imam Muhammad At-Taqi (pbuh) prepared the Muslims for the time when the 12th Imam would come. He did this by training the Muslims to ask questions and take advice from those who had learnt the Qur'an, the laws of Islam and who were muttaqee (those with taqwa - who did all the wajib things and did not do haram things). This is called taqleed.

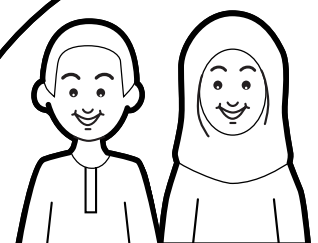

After Ma'mun died the bad ruler Mu'tasam arranged for Imam to be poisoned.

Imam was only 25 years old when he was poisoned and he is buried near his grandfather in Kadhmain (Iraq). His wafat (death day) is on the 29th of Dhulqa'da 220 A.H.

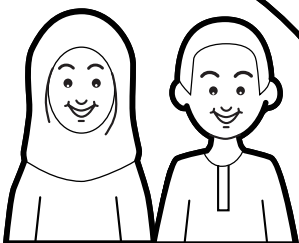

Imam Muhammad At-Taqi (pbuh)

From the story in your manual (pg 57) - what did Ma'mun have in his hands?

Join the dots and colour the picture.

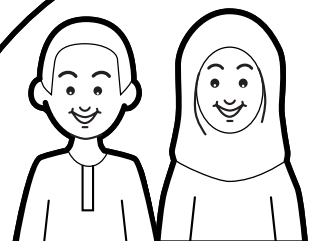
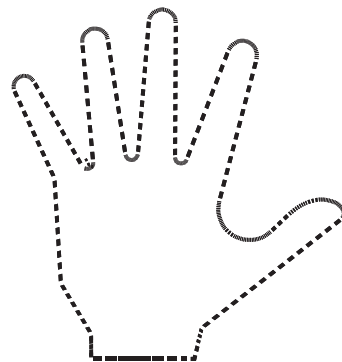
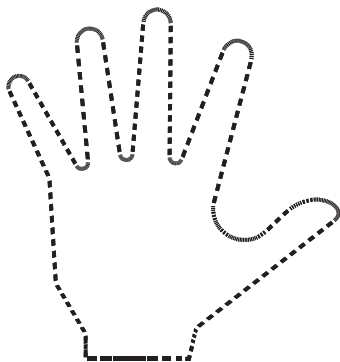
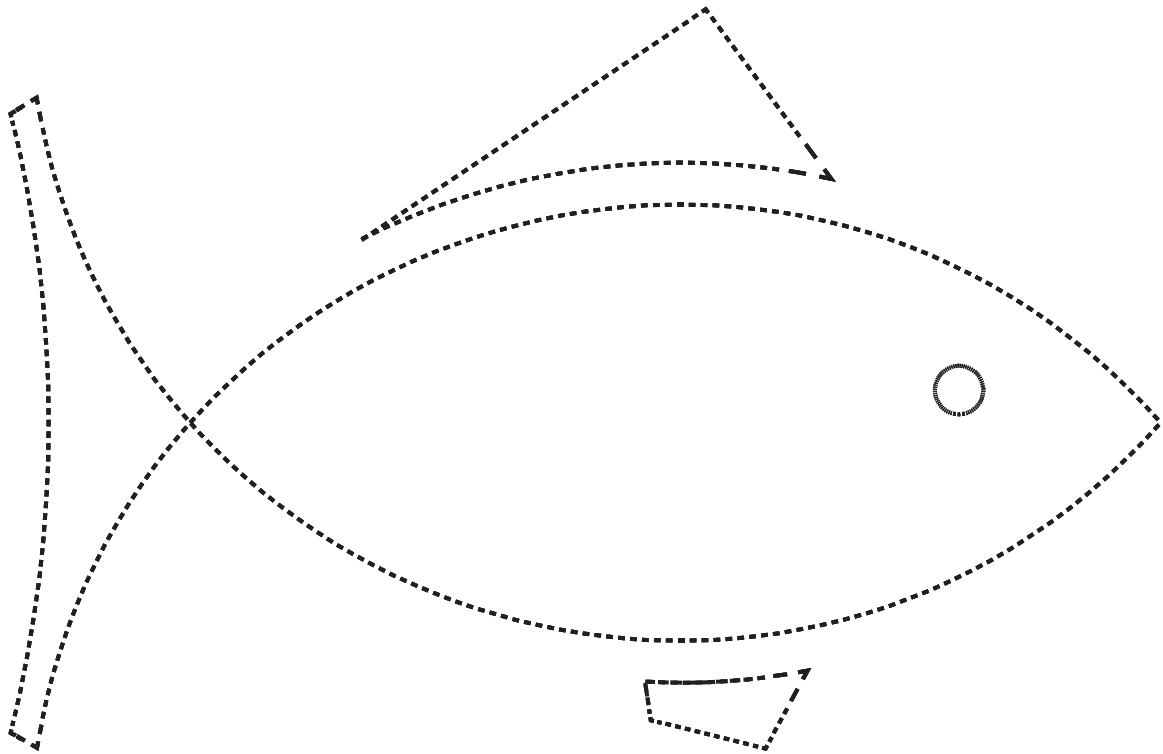

10 - IMAM ALI AN-NAQI (pbuh)

He was born in Surba (a district of Madina) on 15th Dhulhijja 212 A.H.

His father is Imam Muhammad At-Taqi (pbuh) and his mother was Sayyida Sumaanaa.

The ruler of the time was a bad man called Mutawakkil. Like Saddam Tikriti he too tried to destroy the shrine of Imam Husayn (pbuh) and was very cruel. He even tried to flood the grave of Imam Husayn (pbuh) so nobody would know where it was. He did not like anyone to visit Karbala. Imam Ali An-Naqi (pbuh) encouraged people to visit Karbala even though it was very difficult. He told them to do majalis of Imam Husayn (pbuh) as much as possible.

He, like his father also prepared the rules of taqleed - to follow someone who knows the Qur'an, laws of Islam, and has taqwa. This was to prepare Muslims for the ghayba of Imam Muhammad Al-Mahdi (pbuh)

Imam Ali An-Naqi (pbuh) opened schools (madradas) in Madina where many students came to study. The bad ruler Mutawakkil did not like this and summoned Imam to Samarra where he would not let Imam leave his house or let anyone visit him (kept him under house arrest).

Another bad ruler called Mu'taz poisoned Imam and he died on the 3rd of Rajab 254 A.H.

He is buried in Samarra (Iraq).

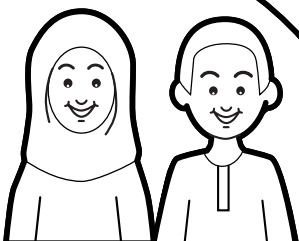

11 - IMAM HASAN AL-ASKERY (pbuh)

Imam Hasan Al-Askery (pbuh) was born in Madina on the 10th of Rabi ul Aakher 232 A.H.

His father is Imam Ali An-Naqi (pbuh) who is our 10th Imam and his mother was Sayyida Sulail.

Once when he was a little boy he fell into a well near his house. His father was praying salaa and his mum started crying. When Imam Ali An-Naqi (pbuh) finished praying he was told what had happened. Smiling he went to the well. The water rose up to the top and the young Imam Hasan Al-Askery was sitting on it.

Imam Hasan Al-Askery (pbuh) was put into prison from a young age. The prison was a tunnel under the bad ruler's bedroom with no space to stand or lie down. His daily meal was a piece of dry bread and a glass of hot water.

Like his father and grandfather, he prepared the Muslims for the ghayba of Imam Muhammad Al-Mahdi (pbuh) He compiled all the laws of fiqh completing his fathers' work. He also set up a system whereby people could contact his representatives. This system today in the ghayba of Imam helps us to turn to the mujtahideen when we are in need of guidance.

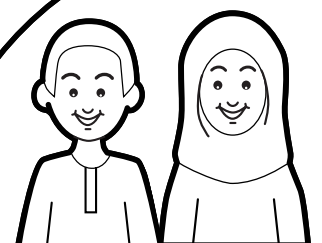

He was poisoned by the bad ruler Mu'tamad. The poison made him very ill and he was in pain for 8 days.

He died on the 8th of Rabi ul Awwal 260 A.H. and is buried in Samarra.

His salaa alal mayyit was led by Imam Muhammad Al-Mahdi (pbuh)

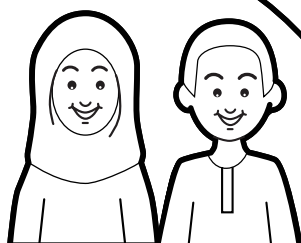

The signs of a Mu'min

Imam Hasan Askery (pbuh)

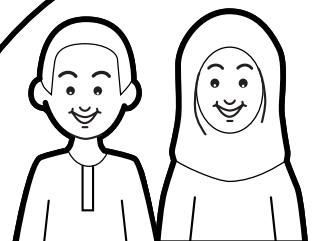
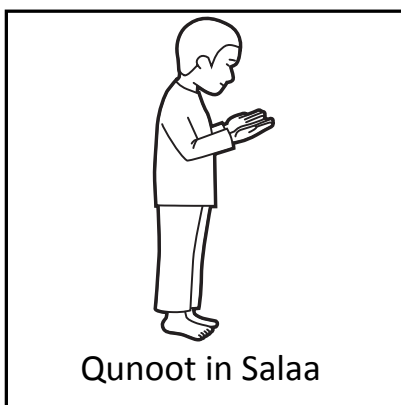
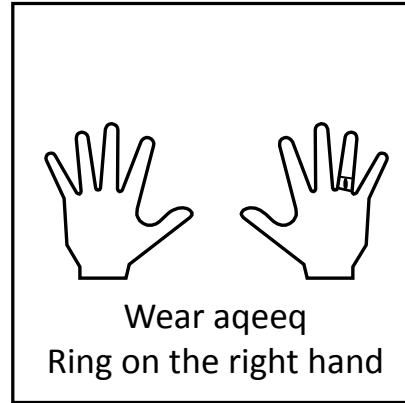
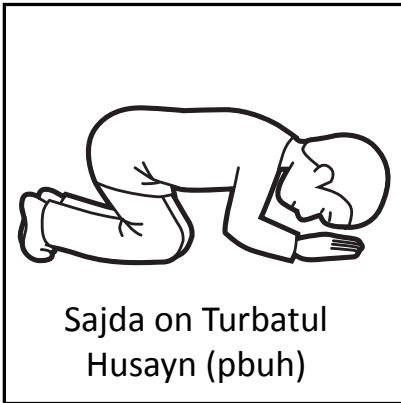

12 - IMAM MUHAMMAD AL-MAHDI (pbuh)

He was born on the 15th of Sha'ban 255 A.H. in Samarra.

His father is Imam Hasan Al-Askery (pbuh) and his mother was Sayyida Nargis.

Imam is still alive and in this year (1417 A.H.) he is 1,162 years old).

He is OUR Imam. Every week he gets a report of what we do from the angels recording our deeds with Allah's permission. He feels very sad when he sees if we have done something that is naughty or bad.

Imam Muhammad Al-Mahdi (pbuh) is in ghayba. This means that although he is amongst us we do not recognise him when we see him.

Whenever we need help we must ask Allah through Imam Muhammad Al-Mahdi (pbuh)

Whenever we hear his name we should bow down, put our hand on our head and recite Salawat.

When Allah orders, Imam will make himself known to us. We must pray to Allah to make this happen quickly and to keep Imam safe.

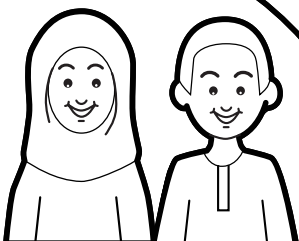

When he makes himself known to the world, he will want us to be his soldiers so that the world can be a better place. A world of justice. We should prepare to be his soldiers by being the best of Muslims - by having taqwa (keeping away from all haram acts and doing all the wajib acts).

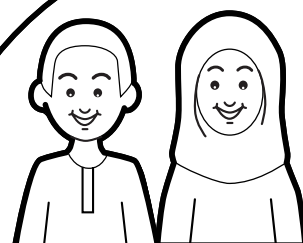

Imam

Imam means Leader

Circle all the things you would do as a follower for your Imam -
Imam Muhammad Al-Mahdi (pbuh)

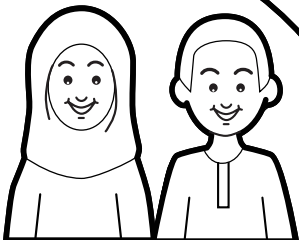
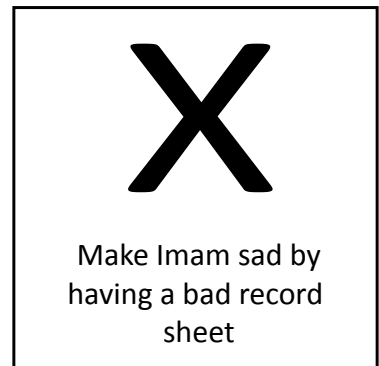
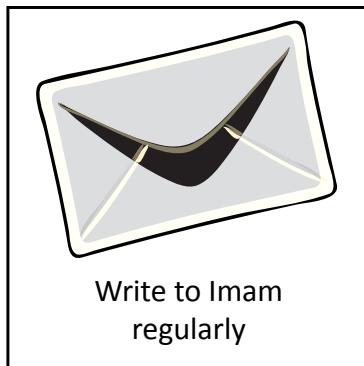
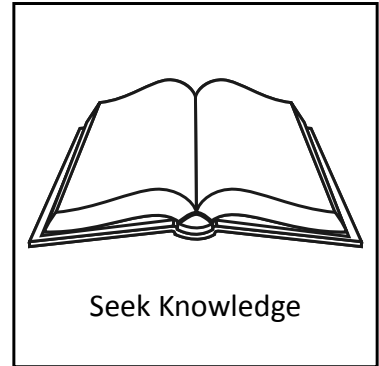
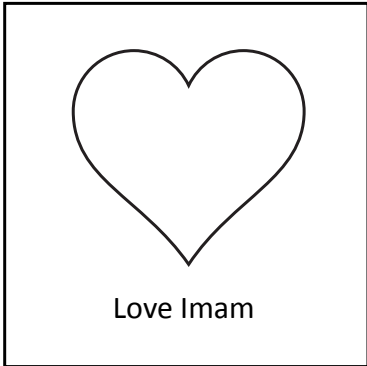
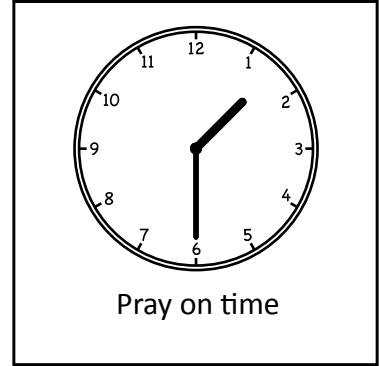
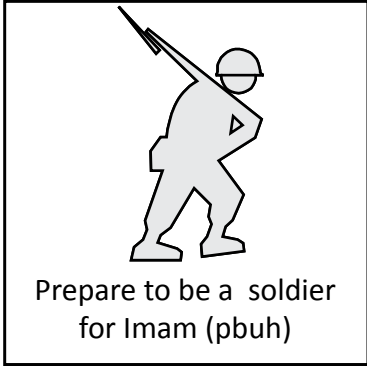

Imam Zamana (pbuh)

Put the first letter of each picture into the adjacent box to find one of the titles of Imam.

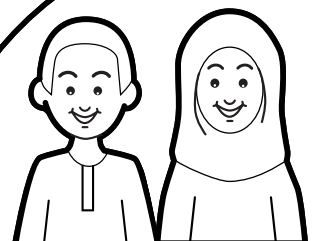
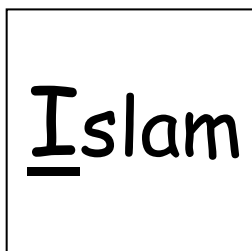
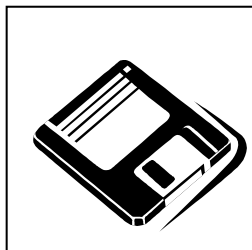
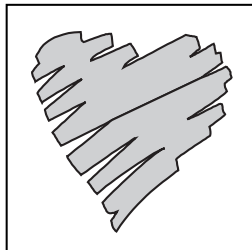
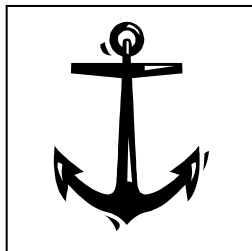
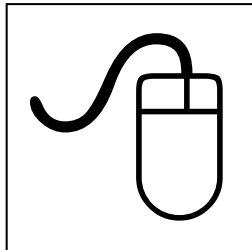

THE ISLAMIC YEAR

There are 12 months in a year.

As a Muslim I follow the Lunar calendar.

The Lunar month is the time between two new moons. Lunar comes from the Latin word Luna which means moon. A Lunar month is either 29 or 30 days long.

The Lunar year is approximately 11 days shorter than the Solar year (January to December).

The months are:

- Muharram
- Safar
- Rabi ul Awwal
- Rabi ul Aakher
- Jamad ul Awwal
- Jamad ul Aakher
- Rajab

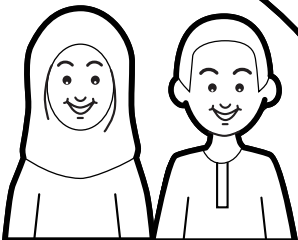

- Sha'ban
- Ramadhan
- Shawwal
- Dhulqa'ada
- Dhul hijja

THE MONTH OF MUHARRAM

It is the opening month of the Islamic year. This is one of the four months declared as sacred by Allah.

The month is of mourning and sorrow. In this month on the tenth day 'Ashura' 61 A.H. (680 C.E.), Imam Husayn (pbuh) his family, relatives and companions were martyred. Majalis are held in this month to commemorate the tragedy of Karbala reminding us that the values of Islam taught by the Prophet (pbuh) must be maintained in their original form under all circumstances.

It is mustahab to fast on the first nine days of the month.

On the day of 'Ashura, it is recommended to remember the martyrs of Karbala, recite Suratul Ikhlas 1000 times and recite the Ziyara of Imam Husayn (pbuh) .

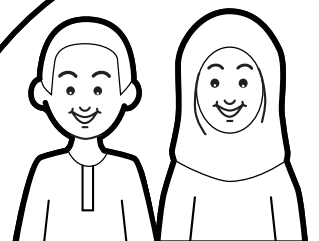

THE MONTH OF SAFAR

The second month of the Islamic year sees the wafat of the Prophet (pbuh) and Imam Al-Ridha (pbuh). It is a month in which the battle of Siffeen was fought by Imam Ali (pbuh)

The 'arba'een of Imam Husayn (pbuh) falls in this month. Imam Hasan Al-Askari (pbuh) has said:

5 things identify a mu'min –

- i) One who prays 51 raka'ts of salaa in a day.
- ii) One who recites Ziyarat Arba'een
- iii) One who wears a ring in the right hand.
- iv) One who uses a 'turbat' for sajda.
- v) One who recites Bismillahirrahmanirraheem loudly in Salaa.

It is recommended to give sadaqa in this month and pray to Allah taking refuge in Him from trials and tribulations.

THE MONTH OF RAJAB

The months of Rajab, Sha'ban and Ramadhan are important months of the Islamic calendar. In many Muslim communities, children are named after these months – such is their greatness.

The Prophet (pbuh) is reported to have said that the month of Rajab is the month when Allah's mercy descends on His creation like gentle rain. He further said that it is the month of Istighfar – a month when one should seek forgiveness of sins.

It is highly recommended to fast in the month of Rajab.

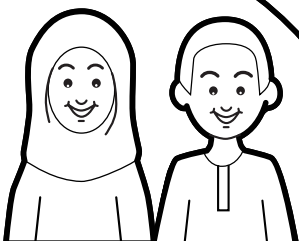

It is also said that there is a river in Janna called Rajab which is whiter than milk and sweeter than honey. The Prophet (pbuh) has said that he/she who fasts in this month will drink from this river.

THE MONTH OF SHA'BAN

The Prophet (pbuh) has said : "Sha'ban is my month and who so ever fasts even once during this month will certainly go to Janna."

Someone once asked Imam Ja'fer As-Sadiq (pbuh) what the best deed was in the month of Sha'ban . He replied :

"To do istighfaar (repent for sins) and to give sadaqa. Sadaqa given in this month would be nurtured by Allah like a camel looks after its young and will be returned on the day of Qiyama".

THE MONTH OF RAMADHAN

The Prophet (pbuh) has said about the month of Ramadhan:

"..It is the month which invites you to be the guests of Allah and invites you to be one of those near Him..."

It is the only month mentioned by name in the Qur'an as the month in which the Qur'an was revealed. It is the month in which we fast and try to get closer to Allah.

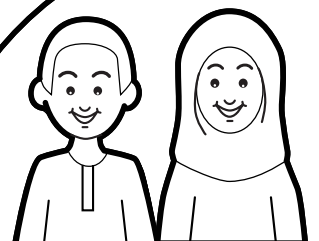

The month of Ramadhan

From the sermon of the Prophet (pbuh)

Truthful Niyya

Pure Heart

Duas

Shaytan locked up

Jahannam closed

Open Janna

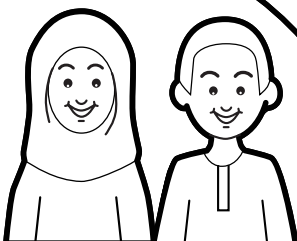
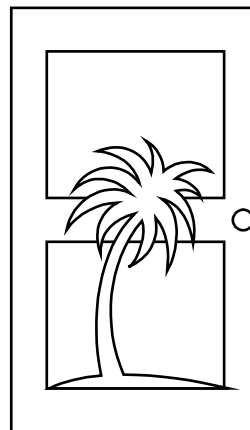
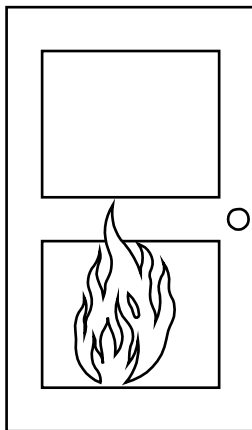
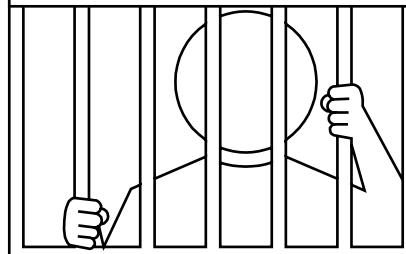

Fasting

Draw and/or write how you fast with part of the body.

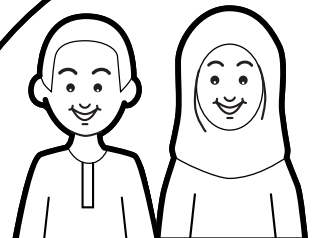
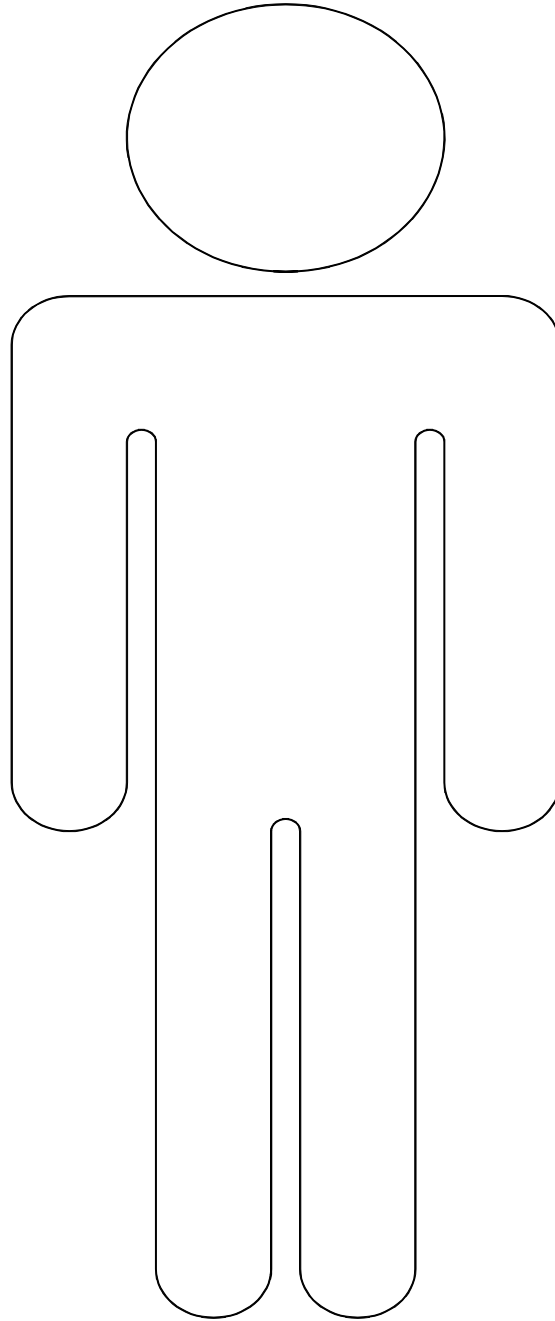

ASSESSMENT

This paper is based on the targets set on the manual for this class.

Name:

Section 1

WUDHOO & SALAA

Adhan	
Iqama	
Niyya	
Takbeeratul Ihram (Action & Recitation)	
Qiyam (Action & Recitation of suwer)	
Qunoot (Action & Recitation of 1 dua)	
Rukoo (Action & Recitation)	
Sijda (Action & Recitation)	
Juloos (Action & Tashahhud & Salaam)	
Tasbee of Bibi Fatima Zahra (pbuh)	

Section 2

When do you say Bismillah, Alhamdulillah, Jazakallah, Insha Allah, & Fiamanillah?

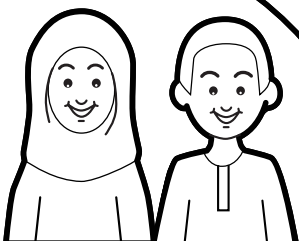

Section 3

How do you make yourself tahir in the toilet?

Section 4

Who is your God?

Who is your Prophet?

What is your book?

What is your qibla?

Who are your Aimma?

Name the first and last Imam?

Try and say the names of all the Aimma in order.

Section 5

Recite Suratul Falaq & Suratun Naas.

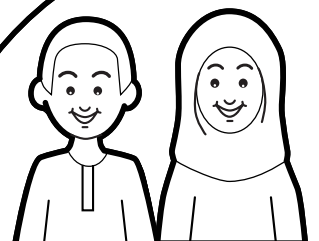

FIQH

Name:

Section 1

Match the columns

What do you say before you start anything?	Takbeeratul Ihram
When you want to say thank you; you say.....	Alhamdulillah
What do you say after you sneeze?	Bismillah
The first wajibat in wudhoo is.....	Jazakallah
The first 'Allahu Akber' in Salaa (namaz) is called.....	Niyya

Section 2

Fill in the blanks

1. In Adhan we recite 'Allahu Akber'.....times
but in Iqama we recite 'Allahu Akber'.....times
2. In Adhan we recite 'La Ilaha Ilallah'.....times

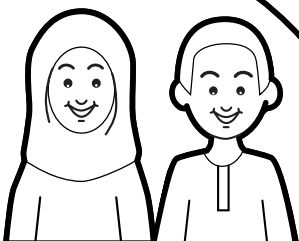

but in Iqama we recite 'La Ilaha Ilallah'.....times.

Section 3

Choose the correct word from the box and fill in the blanks.

Ayatullah Seestani, Mujtahid, 2 times or 3 times, Najis

- a) Fatima wants to learn the rules of Islam. She goes to a
- b) When Zahra visits the toilet, to make herself tahir she must wash herself.....
- c) Our present Mujtahid is
- d) Beer and a dog are both

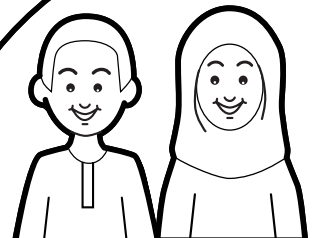

AKHLAQ

ORAL PAPER

1. We should share whatever we have with our Muslims brothers and sisters.

TRUE / FALSE

2. We should choose a friend who has good akhlaq.

TRUE / FALSE

3. We should always thank Allah for our parents.

TRUE / FALSE

4. We cannot go to Janna if our parents are angry with us.

TRUE / FALSE

5. Plants and animals need to be shown respect too.

TRUE / FALSE

6. Eating and drinking until we are completely full is good for us.

TRUE / FALSE

a) Before we speak we must take the mouth test!

What questions should we ask ourselves?

b) How should you greet another Muslim?

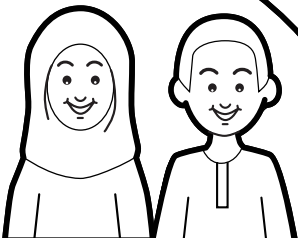

ISLAM IS MY RELIGION

This book has been designed to help a children upto the age of 7 years to achieve the following targets.

RECEPTION (4/5 YEARS)	YEAR 1 (5/6 YEARS)	YEAR 2 (6/7 YEARS)
<p>Usool - Knowing that Allah is One, the Creator, and the Nourisher.</p> <p>Prophet Muhammad (S.A.W.) is the last messenger. Imam Al (A.S.) is the first Imam (leader) after the Prophet (S.A.W.) and the story of Ghadeer.</p> <p><i>Angels</i> <i>Shaytan</i></p> <p>Adhan & Iqama - Recitation</p> <p>Salaa - Must be able to do actions perfectly and recitations with introduction to ta'qibaat of the tasbeeh of Sayyida Fatima (A.S.)</p> <p>Akhlaqiyaat – General ideas of daily activities, friendship and sharing.</p> <p>The Qur'an - Memorisation of 6 suwer - Al-Fatiha, Al-Ikhlās, Al-Falaq, An-Naas, Al-Kaafirun and Al-Qadr.</p> <p>Ambiya - Short stories from the lives of Prophet Adam, Nuh, Ibraheem, Ismail, Musa and Isa (A.S.)</p> <p>Prophet Muhammad (S.A.W.) - Short stories from his life.</p> <p>Ahlul Kisaa - Story of Kisaa.</p> <p>Ma'sumeen - Names and one aspect/aneccode from the life of each Ma'sumeen (taught in the week prior to Wafat/Wiladat).</p> <p>Islamic Year</p>	<p>Usool - Basic concept of Tawheed, Adala, Nabuwwa, Imama and Qiyama.</p> <p>Tahara and Najasa - Basics (especially in the toilet)</p> <p>Wudhoo - Introduction</p> <p>Adhan and Iqama - Recitation</p> <p>Salaa - Must be able to do actions and recitations perfectly. Duas of Qunoot introduced</p> <p>Akhlaqiyaat - Lying/Honesty; Getting angry; manners of talking; watching too much T.V.; respect of parents. Usage of Bismillah, Alhamdulillah, Jazakallah, Insha'Allah, Fiamanillah.</p> <p>The Qur'an - Manners of recitation. Memorisation of 10 suwer - Al-Fatiha, Al-Ikhlās, Al-Falaq, An-Naas, Al-Kafirun, Al-Kawthar, Al-Qadr, Al-Feel, AL-Lahab, and Al-'Asr.</p> <p>Ambiya - Short stories from the lives of Prophet Yunus, Ibraheem, and Sulayman (A.S.)</p> <p>Prophet Muhammad (S.A.W.) - Short stories from his life.</p> <p>Ma'sumeen - Names and one aspect/aneccode from the life of each of the Ma'sumeen (taught in the week prior to Wafat/Wiladat).</p> <p>General Knowledge - Be able to identify the Ka'ba, Masjidun Nabi, and Masjidul Aqsa and know their locations.</p> <p>Islamic Year</p>	<p>Usool - Simple explanations</p> <p>Fiqh terminology - Wajib, Haram, Mustahab, Makruh, Ja'iz, Adhab, Thawab.</p> <p>Tahara and Najasa Wudhoo</p> <p>Salaa - Pre-requisites i.e. Qibla, and times of Salaa. Should be able to do actions and recitations of Salaa perfectly including recitation of Adhan and Iqama.</p> <p>Akhlaqiyaat - Not to abuse or belittle others, not to be extravagant, being cheerful and the concept of big and small sins.</p> <p>The Qur'an - Manners of recitation and basic terminology. Memorisation of 12 suwer and Ayatul Kursi. Translation and explanation of Suratul Kawthar, Suratul 'Asr, Suratul Feel and Suratul Lahab.</p> <p>Ambiya - Short stories from the lives of Prophet Dawud and Sulayman (A.S.)</p> <p>Prophet Muhammad (S.A.W.) - Family tree, birth, be'that, me'raj, hijra, Ghadeer and wafat..</p> <p>Ma'sumeen - Names and one aspect/aneccode from the life of each Ma'sumeen (taught in the week prior to Wafat/Wiladat). Basic knowledge of each Imam.</p> <p>General Knowledge - Knowledge of basic facts - 1 billion Muslims worldwide, 52 Muslim countries, location of Makka, Madina, Baytul Muqaddas, Karbala on the map.</p>



Hujjat Saturday Workshop
Wood Lane, Stanmore, Middlesex HA7 4LQ
www.hujjat-workshop.org